

## 1 INTRODUCTION

GNS603 is a small autonomous GPS receiver, based upon the MT3339 single chip, available with a finely tuned, high-sensitivity patch ceramic antenna.

The navigation performance and accuracy is further improved by using correction data from SBAS (WAAS, EGNOS, GAGAN, MSAS, QZSS).

The GNS603 provides an extra embedded functionality for connection of an external active GPS antenna. An automatic antenna switching function and a short circuit protection features a software antenna status message called "Antenna Advisor". The "Antenna Advisor" helps to indicate the different states, including active antenna connection, antenna open circuit detection and antenna shortage.

First Fixes after just a few seconds are achieved with the help of A-GPS using EPO™ ( Extended Prediction Orbit) and the EASY™ "self generated orbit prediction" algorithm. EASY™ (Embedded Assist System) does not require any resources or assist data from the host.

The excellent low power design makes it easy to implement this receiver in power sensitive, battery supplied applications. The new AlwaysLocate™ power management feature will improve this behaviour additionally. It adaptively adjusts power consumption depending on the environment and motion conditions, in order to achieve a balance between fix rate, power consumption and position accuracy.

Very low power requirements (typ 66mW@ 3.3V) and internal voltage regulator makes it easy to run the receiver with various power supplies and allows direct connection to LiIon batteries.

GNS603 offers the industry's highest level of navigation sensitivity up to -165dBm<sup>1</sup>. It has superior dynamic performance at high velocity and provides effective protection against interference signals using MTAIC™ ( Multi-tone active interference canceller). Up to 12 independent channel interference continuous wave jammers <-80dBm can be eliminated or reduced.

The embedded logger function LOCUS with a 16-hrs on chip memory makes this GPS module a complete track logger for many applications. With AlwaysLocate™ data logging can be achieved up to 32-hrs under standard conditions.

In professional timing applications the outstanding high accuracy PPS (pulse per second) hardware pin is used for synchronization to GPS second. Typical accuracy is 10ns.

1 note: Based on chip specifications

## **FEATURES**

- 66 acquisition-/ 22 tracking channels
- Ultra high tracking/navigation sensitivity: -165dBm<sup>1</sup>
- Smart antenna: finely tuned ceramic patch antenna
- Automatic external/internal antenna switching function
- "Antenna Advisor" function
- SBAS (WAAS, EGNOS, MSAS, GAGAN, QZSS) correction support
- A-GPS by EPO "Extended Prediction Orbit"™ enables 7/14days prediction
- 12 Multitone Active Interference Canceller (MTAIC) for GPS-in-band jammer rejection
- EASY™ : Self generated orbit prediction support
- AlwaysLocate™ : Intelligent Algorithm for power saving
- High accuracy 1PPS output
- NMEA-0183 or binary protocol
- High update rate (up to 10/s)
- Embedded logger function with 16hrs internal memory
- GPS current consumption (@3.3V):
  - Acquisition: 25mA Typical
  - Tracking: 20mA Typical
- Low backup current consumption 7uA, typical
- SMD type with stamp holes
- Small form factor: 16x16x5.2mm
- CE, FCC and RohS certified

<sup>1</sup> note: Based on chip specifications

**2 INDEX**

1 INTRODUCTION	1
2 INDEX	3
3 FUNCTIONAL DESCRIPTION	4
3.1 System description	4
3.2 Block diagram	4
3.3 AGPS with EPO data	5
3.4 Power Management Features	6
3.5 EASY™ self generated prediction data feature	7
3.6 Pulse Per Second (PPS)	8
3.7 Antenna Advisor	9
3.8 Antenna Status Message	9
3.9 Logger function	9
3.10 Active interference cancellation (MTAIC)	10
3.11 SBAS (Satellite Based Augmentation) support	10
3.12 Single sentence output	10
3.13 Last position retention	10
3.14 Geofencing function	11
3.15 Magnetic variation feature	11
3.16 Distance calculation feature	11
3.17 GPS almanac and ephemeris data	11
3.18 Real time clock (RTC)	11
3.19 UART interface	11
3.20 Module default settings	12
4 TYPICAL APPLICATION BLOCK DIAGRAM	12
4.1 Typical System Overview	12
5 GPS characteristics	13
5.1 GPS characteristics	13
6 DESIGN GUIDELINES	14
7 ELECTRICAL SPECIFICATION	14
7.1 Absolute Maximum Ratings	14
7.2 Recommended Operating Conditions	14
7.3 Recommended External GPS Antenna Specification	14
8 PIN CONFIGURATION	15
9 PHYSICAL DIMENSIONS	17
10 RECOMMENDED PAD LAYOUT	18
11 NMEA DATA interface	19
11.1 NMEA output sentences	19
11.2 NMEA command interface	19
12 MATERIAL INFORMATION	20
13 RECOMMENDED SOLDERING REFLOW PROFILE	20
14 TRAY PACKAGE INFORMATION	21
15 TAPE&REEL INFORMATION	21
16 ORDERING INFORMATION	22
17 FCC COMPLIANCE	23
18 ENVIRONMENTAL INFORMATION	23
19 MOISTURE SENSITIVITY	23
20 DOCUMENT REVISION HISTORY	23
21 RELATED DOCUMENTS	24

### 3 FUNCTIONAL DESCRIPTION

#### 3.1 System description

The GNS603 is a high performance, low power GPS receiver that includes an integrated RF frontend (SAW Filter + LNA) and a finely tuned 15x15x2mm ceramic patch antenna.

Due to high input sensitivity and integrated low noise amplifier (LNA), it can work at very weak GPS signals.

GNS603 is a complete autonomous GPS receiver, including:

- Full GPS processing, without any host processing requirements
- Standard NMEA message output
- A powerful NMEA command and control interface
- All clock sources integrated
- RF frontend integrates a low noise amplifier (LNA) and a SAW filter
- Rich additional features like geofencing, single sentence output, last position retention, magnetic variation, distance calculation
- Interface for UART, PPS output pin, Fix Status Indicator pin

#### 3.2 Block diagram

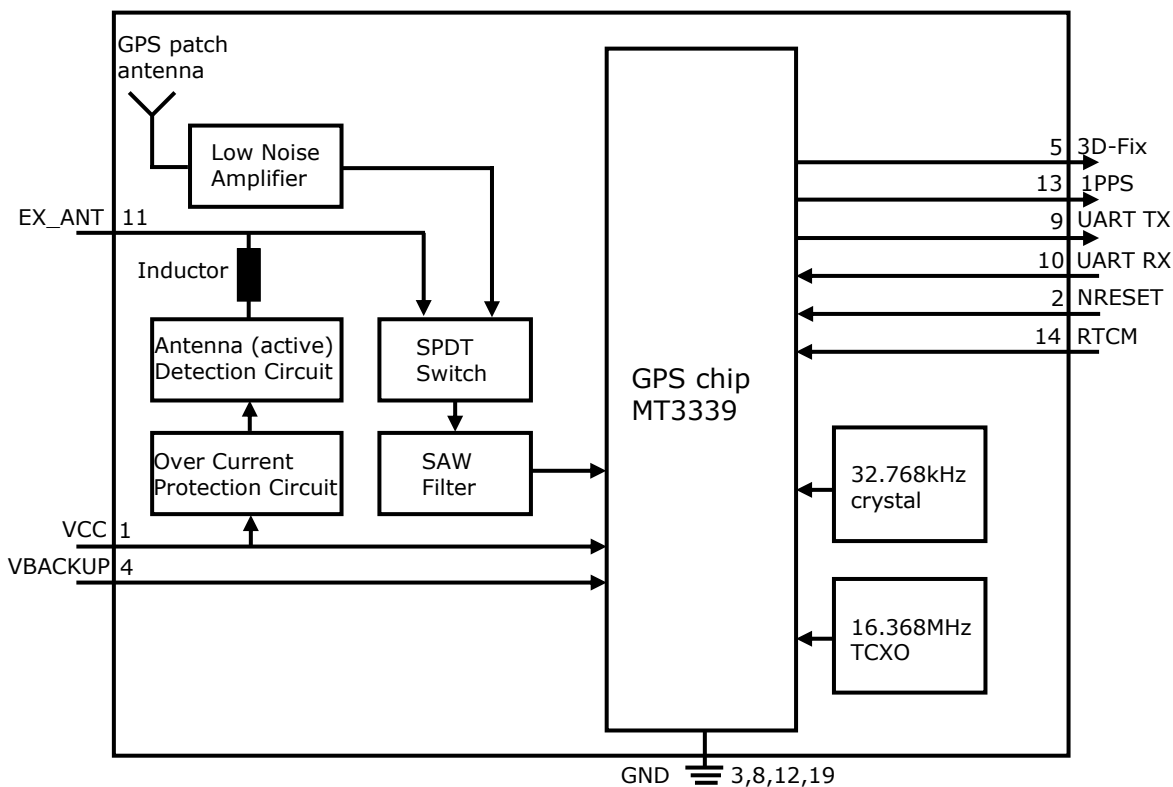

### 3.3 AGPS with EPO data

AGPS (assisted GPS) allows to shorten TTFF (TimeToFirstFix) by injecting ephemeris data from an external source into the module's memory. With the help of these data, the module does not need to acquire satellite positions by receiving the data from the satellites.

Depending on time and position information, that is still available in the module memory, the TTFF can be reduced to just a few seconds.

The GNS AGPS service is based on a short term predicted data service. The predicted data will be fully processed by the GPS engine. The host must load the data from the web and transfer them over the UART into the module:

1. Check GNS603 module EPO (Extended Prediction Orbit) data for validity by comparing the time.
2. Connect to web server through network connection (GPRS, WLAN, LAN,..).
3. Download file. There are just two files, covering all GPS satellites. The first file (MTK7d.EPO) is for 7 days (53kB), the other is 106Kbytes for 14 days (MTK14d.EPO)
4. "Parse" file, using software example. This is quite easy, there must be added some header bytes and a checksum and a control counter. GNS offers software support on this.
5. Download to GNS603 receiver. Please refer to the *NMEAcommandInterface manual* for details.

If the host has low memory available, there's no need to save the whole file. The steps 3..5 can be done frame by frame needing less than 2kBytes of buffer memory.

Code samples and support for several platforms are available from GNS (in preparation).

Thanks to the predicted system, download data stay valid for up to 14 days. Therefore, users can initiate the download everytime and benefit from using (W)LAN instead of using expensive GSM. File size will be ~50kBytes for a one week prediction data set.

AGPS characteristics					
System					6hrs predicted data
File size for data download		53		kB	1 week prediction data
Maximum prediction time	7	14		days	
TTFF		1		sec	Time and last position available
TTFF		15		sec	Last position available

### 3.4 Power Management Features

Power management schemes implemented for any GPS system requires an optimally tuned performance for both accuracy of the position fixes and the average power consumed for best user experience. GNS603 architecture achieves these both aspects by providing flexibility and design choices for the system integration, based on wide range of use cases and by leveraging on the proven silicon methodologies. Also GNS603 provides position, velocity and time measurements without any host loading. This, coupled with the optional built-in power management options, reduces the overall system power budget.

Selectable Power management features:

- In **Standby mode** RF frontend and internal MPU are switched to deep sleep state. Power consumption is reduced. This state can be entered by sending the NMEA command: \$PMTK161,0\*28<CR><LF>. Leaving standby mode and resuming to normal operation will be managed by sending any byte to the module.

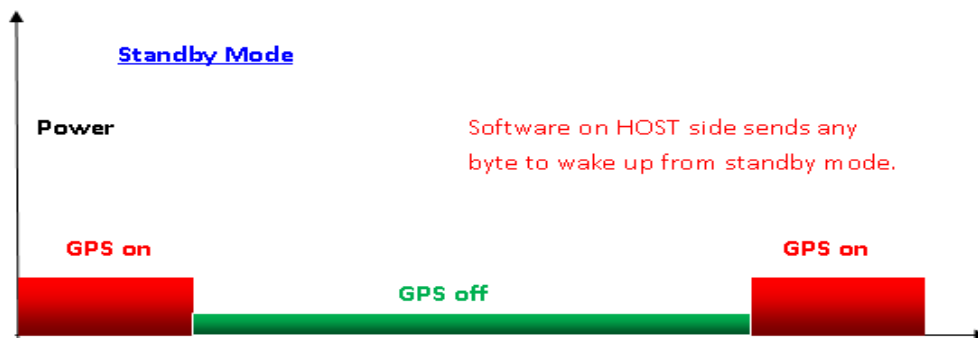

- **Backup mode** can be entered by sending NMEA command: \$PMTK225,4\*2F<CR><LF>. The GPS core will shut down autonomously to backup state, Vcc supply can now be switched off by an external power supply switch.
- **Periodic mode** describes a power mode, which will autonomously power on/off the module in programmable time slots with reduced fix rate. Periodic mode is useful during stationary operation or if position fixes are just needed from time to time. Since power consumption in **GPS off** times is nearly zero, the power consumption in periodic mode can be estimated by  $P_{\text{tracking}} * (t_{\text{on}} / (t_{\text{on}} + t_{\text{off}}))$ . Periodic mode is controlled with NMEA command \$PTMK225. See document *NMEAcommandInterface manual* for programming details.

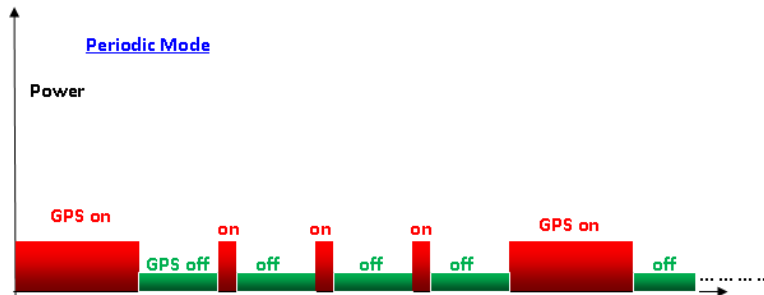

- **AlwaysLocate™** feature provides an optimized overall GPS system power consumption in tracking mode under open sky conditions. Always Locate is an intelligent control of periodic mode. Depending on the environment and motion conditions, GNS603 can adjust the on/off time to achieve balance of positioning accuracy and power consumption. The best power saving will be made under good reception in stationary mode. Critical reception conditions and dynamic movements will need full activity of the GPS engine which causes nominal power requirements (20mA typ in tracking mode).

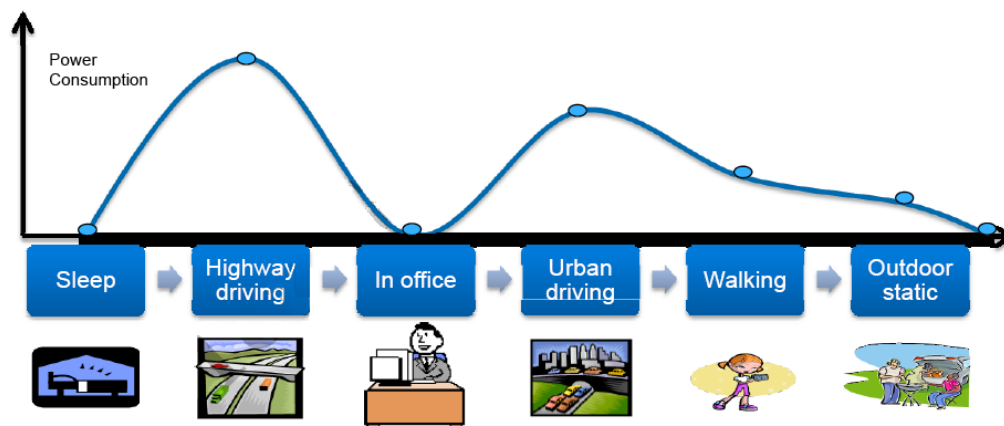

### 3.5 EASY™ self generated prediction data feature

GNS603 includes an internal prediction system, that allows to sample satellite orbit data during operation and use that data to speed up TTFF on later starts. The prediction time frame is up to three days forward.

Although this prediction feature does not provide the very short TTFF that is achieved using AGPS, it can help to find a fix solution faster and in weak signal condition scenario. Prediction data will be kept in memory as long as VBACKUP is present. This option is activated by default.

**Note:** The EASY functionality is only supported, if "VBACKUP" pin is connected and the NMEA update rate is 1Hz.

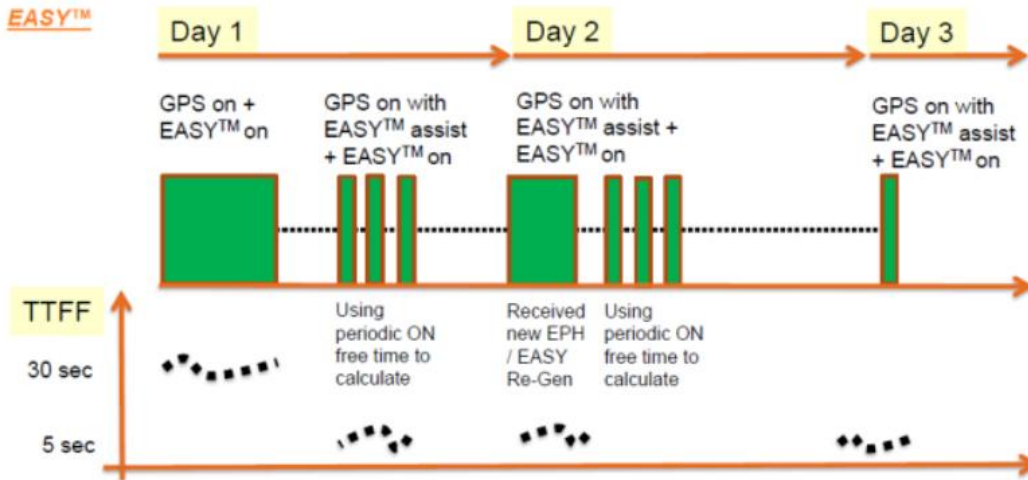

### 3.6 Pulse Per Second (PPS)

GNS603 provides a Pulse Per Second (PPS) hardware output pin for timing purposes. After calculation of a 3D position fix (default setting), the PPS signal is accurately aligned to the GPS second boundaries. The pulse generated is approximately 100 milliseconds in duration and the repetition rate is 1 second. On request PPS output can be activated on a 2D-fix or after power-up of the module, providing a time accuracy decreased PPS signal.

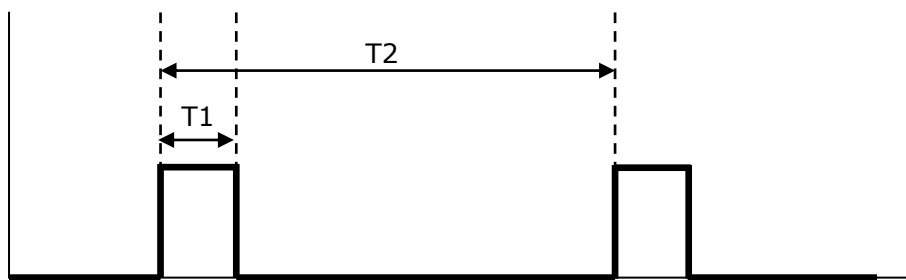

T1 = 100ms T2 = 1sec

GNS603 module provides an exceptionally low RMS jitter of typical 10 nanoseconds.

PPS characteristics based upon a 3D-fix					
1PPS pulse duration	-	100	-	msec	
1PPS time jitter	-	10		nsec RMS	Pulse rising edge deviation from expected pulse time, measured with full 3D fix
1PPS rise and fall time		5		nsec	10%..90%, load is 10k  5pF



### 3.7 Antenna Advisor

The Antenna Advisor function is designed to detect and notify the actual status of an external active antenna by using a proprietary software protocol. The following states can be detected:

- Active antenna shorted
- Using internal antenna
- Using active antenna

Once this function is enabled, the antenna status message \$PGNS,11,value is cyclic outputted after each NMEA data set.

The antenna status message can be en-/disabled by using \$PGCMD,33 command:

Example:

```
$PGCMD,33,mode*checksum<CR><LF>
```

Mode: 0 → disable this message

1 → enable this message

```
$PGCMD,33,0*6D<CR><LF>
```

```
$PGCMD,33,1*6C<CR><LF>
```

### 3.8 Antenna Status Message

The antenna status message displays the detected GPS antenna status changing the value flag.

Antenna Status Message			
Name	Example	Unit	Description
Message ID	\$PGNS		Protocol header
Command ID	11		Function Type
Reference	value		Value of antenna status

Value:

1=> Active Antenna Shorted

2=> Using Internal Antenna

3=> Using Active Antenna

Example:

```
$PGNS,11,value*checksum
```

### 3.9 Logger function

GNS603 provides an autonomous logger function that automatically stores position information in an internal 128kB flash memory. A complete tracking unit can be realized without any external CPU or memory.

The parameters for logging are programmable via the NMEA command interface. The following parameter can be set to optimize logging time:

- logger rate

The commands for logger include:

- start logging
- stop logging
- erase memory
- readout memory

Please refer to the *NMEACommandInterface manual* for details.

Internal Logger Function					
Logger data rate	1/15		1	1/s	
Logger data memory		128		kBytes	Flash memory
Logger trigger		programmable			Logger can be triggered on various events

### 3.10 Active interference cancellation (MTAIC)

Because different wireless technologies like Wi-Fi, GSM/GPRS, 3G/4G, Bluetooth are integrated into portable systems, the harmonic of RF signals may influence the GPS reception.

The multi-tone active interference canceller can reject external RF interference which come from other active components on the main board, thus improving the performance of GPS reception.

GNS603 can cancel up to 12 independent continuous wave (CW) channels having signal levels of up to -80dBm. The functionality is enabled by default and increases power consumption by about 1mA.

### 3.11 SBAS (Satellite Based Augmentation) support

GNS603 supports Satellite Based Augmentation for improvement of the navigation precision.

Correction data is sent from geostationary satellites to the GPS receiver. GNS603 supports European, US, and Asian augmentation systems (EGNOS, WAAS, GAGAN, MSAS, QZSS) to enable precision improvements in nearly every region of the world.

SBAS is active by default and will automatically track the available SBAS satellites. It can be disabled by NMEA command. See document *NMEACommandInterface manual* for details

**Note** : In SBAS mode, the maximum NMEA sentence update rate is limited to 5 per second.

### 3.12 Single sentence output

GNS603 allows to reduce data transfer to host to a minimum. Reduced data transfer can save host processor activity times and thus reduce system power consumption. All relevant information will be provided in a single sentence output. To save further channel load, the sentence can be formatted as binary. Need of firmware customization.

### 3.13 Last position retention

Depending on the application, it might be useful to retain the last position or to clear the position when having no fix solution. Last position retention can be enabled or disabled. When enabled, the last known position is outputted in the NMEA sentences. Need of firmware customization.

### 3.14 Geofencing function

GNS603 has an internal algorithm to determine whether the actual position is within a circular area around a predefined location point. A proprietary sentence indicates the "inside" or "outside" status. Need of firmware customization.

### 3.15 Magnetic variation feature

As the magnetic variation feature is enabled, data output provides informations about the degree of magnetic variation and the measured magnetic heading. Need of firmware customization.

### 3.16 Distance calculation feature

This feature allows to request the real "line of sight" distance in relation to a predefined position. This feature can remove some load from the host processor. Need of firmware customization.

### 3.17 GPS almanac and ephemeris data

For quick re-acquisition of the GPS after off-times, the GPS engine should have access to almanac and ephemeris data. This data is permanently stored inside GNS603 module, even if all power supplies have been removed. When the GPS is powered-up again, the data will be used to allow a quick re-acquisition, as soon as a coarse time information is available. Time will be available immediately, when RTC is kept running.

### 3.18 Real time clock (RTC)

GNS603 has a real time clock with 32,768Hz crystal onboard. As long as VBACKUP is connected to a power source, the real time clock and the module memory can be kept alive at very low power consumption of just 7uA. The RTC will track the current time and enable the module to start from sleep states with very fast time to first Fix (TTFF).

### 3.19 UART interface

GNS603 core and I/O sections work at 3.3V nominal. Absolute Maximum Ratings should not be exceeded. Should the GNS603 be interfaced to a host with I/O at higher/lower levels, level shifters should be used. UART baud rate is 9600baud by default. The baud rate can be modified to higher rates by a NMEA software command. See document *NMEACommandInterface manual* for details.

**GPS UART Default Settings**

Parameter	Value
Baud rate	9600
Data length	8 bits
Stop bit	1
Parity	None

### 3.20 Module default settings

The GNS603 receiver comes with default settings, which are persistently programmed. Whenever power is removed from the module (both VCC and VBACKUP), the settings will be reset to the values shown in the following table.

<b>NMEA output sentences</b>	
<b>Setting</b>	<b>Default value</b>
UART setting	9600,8,N,1
Fix frequency (update rate)	1/sec
NMEA sentences	\$GPRMC,\$GPGSA,\$GPGSV,\$GPGGA,\$GPVTG
NMEA rate	Once a second: RMC,GSA,VTG,GGA every 5 sec :GSV sentences
Self survey prediction mode: EASY™	enabled
Active interference cancellation:MTAIC	enabled
Datum	WGS 84
Logging parameters	Full&Stop / Content Basic / Interval 15 sec
Single sentence output	Customized firmware needed
Last position retention	Customized firmware needed
Magnetic variation	Customized firmware needed
Geofencing function	Customized firmware needed
Distance calculation	Customized firmware needed

On request, other options can be selected as preprogrammed (persistent default) options. Please contact the GNS support for your project requirements.

**Note :** Customized options are solely available for fixed order lots.

## 4 TYPICAL APPLICATION BLOCK DIAGRAM

### 4.1 Typical System Overview

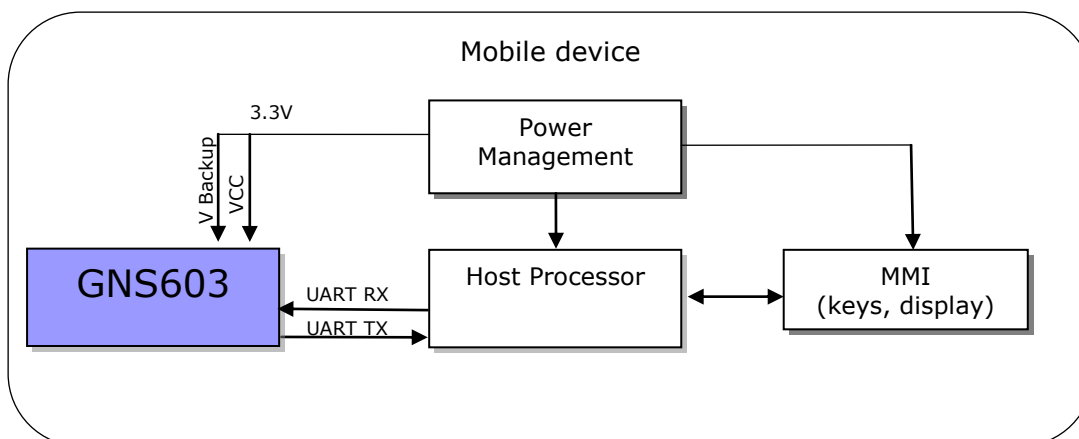

## 5 GPS characteristics

5.1 GPS characteristics					
Parameter	Min	Typ	Max	Unit	Note
General					
Frequency		1575.42		MHz	GPS L1 C/A code
SBAS					WAAS, EGNOS, MSAS, GAGAN, QZSS
Datum					WGS84
AGPS	7		14	days	Configurable
Output data frequency	1/10	1	10	1/sec	
Navigation&tracking sensitivity <sup>1</sup>		-165		dBm	autonomous
Acquisition sensitivity <sup>1</sup>		-148		dBm	Cold start
Reacquisition sensitivity <sup>1</sup>		-163		dBm	Hot start
TTF hotstart <sup>1</sup>		1		sec	All SVs @-130dBm
TTF autonomous warm start <sup>1</sup>		34		sec	All SVs @-130dBm
TTF autonomous cold start <sup>1</sup>		35		sec	All SVs @-130dBm
Reacquisition time <sup>1</sup>		<1		sec	All SVs @-130dBm
Number of channels tracking		22			
Number of acquisition channels		66			
Dimension		16x16x5.2		mm	Tolerance is 0.2 mm
Weight		4		g	
Power consumption					
GPS ACTIVE (acquisition)		25		mA	NMEA frequency = 1/sec, 3.3V; SBAS enabled; MTIAC enabled
GPS ACTIVE (tracking)		20		mA	NMEA frequency = 1/sec, 3.3V; SBAS enabled; MTIAC enabled
Backup current @ 3V		7		uA	

Accuracy					
Position error (50%CEP)	-	3	-	m	Without aid 2D-RMS
Position error (50%CEP)	-	2.5	-	m	Using (SBAS) 2D-RMS
Velocity error	-	0.1	-	m/s	Without aid
velocity error	-	0.05	-	m/s	Using (SBAS)

ITAR limits					
Operation altitude		-	18,000	m	
Operation velocity	-	-	515	m/s	
Operation acceleration	-	-	4	G	

<sup>1</sup> note: based on chip specifications

## 6 DESIGN GUIDELINES

Although GNS603 GPS receiver provides best performance at low power consumption. Special care should be taken to provide clean signal and clean power supplies. Power lines should be blocked near to the receiver with low ESR capacitors.

Radiated noise from neighbour components may also reduce the performance of the receiver. Please refer to "GNS603 Starter Kit User Manual" for more informations, downloadable at the GNS forum: [www.forum.gns-gmbh.com](http://www.forum.gns-gmbh.com) .

## 7 ELECTRICAL SPECIFICATION

7.1 Absolute Maximum Ratings		
Parameter	Value	Unit
Supply voltage range: Vcc	3.0 to 4.3	V
Backup voltage: VBACKUP	2 to 4.3	V

7.2 Recommended Operating Conditions					
Parameter	Min	Typ	Max	Unit	Note
V <sub>cc</sub>	3.0	3.3	4.3	V	supply voltage
V <sub>cc</sub> ripple voltage				50	mVpp
VBACKUP	2.0	3.0	4.3	V	Backup voltage for RTC and memory retention, must be available during normal operation
RX0 TTL H Level	2.0		V <sub>cc</sub>	V	Condition: VCC=3.0V~4.3V
RX0 TTL L Level	0		0.8	V	Condition: VCC=3.0V~4.3V
TX0 TTL H Level	2.4		2.8	V	Condition: VCC=3.0V~4.3V
TX0 TTL L Level	0		0.4	V	Condition: VCC=3.0V~4.3V
Storage temperature	-50		+90	°C	
Operating temperature	-40		+85	°C	

7.3 Recommended External GPS Antenna Specification	
Characteristic	Specification
Polarization	Right-hand circular polarized
Frequency	1.57542GHz +/- 1.023MHz
DC Power Supply	3V to 3.6V
DC Current	4mA ~ 25mA at 3.3V
Total Gain	< 25dB
Output VSWR	< 2.0
Impedance	50ohm
Noise Figure	< 1.5dB

**8 PIN CONFIGURATION**

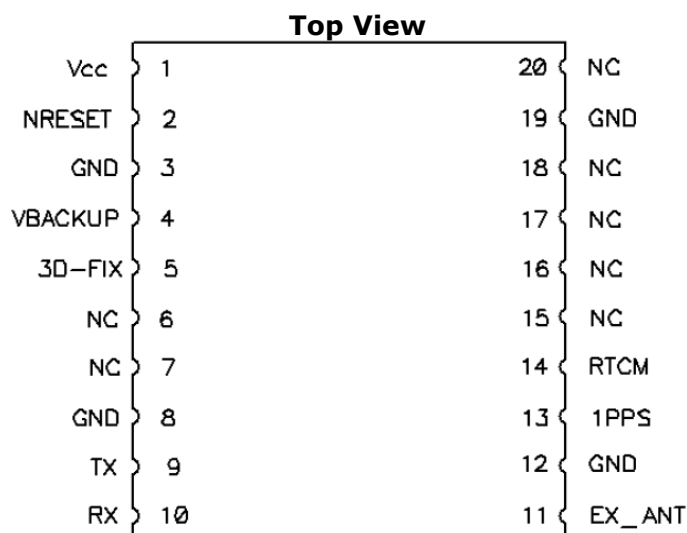

Pin	Name	I/O	Description & Note
1	VCC	PI	<b>Main DC power input</b> The main DC power supply for the module. The voltage should be kept between from 3.0V to 4.3V. The ripple must be limited under 50mVpp (Typical: 3.3V).
2	NRESET	I	<b>Module Reset</b> At low signal level the module performs a reset. If not used, keep floating.
3	GND	P	Ground.
4	VBACKUP	PI	<b>Backup power input for RTC &amp; navigation data keep</b> This connects to the backup power of the GPS module. Power source (such as battery) connected to this pin will help the GPS chipset in keeping its internal RTC running when the main power source is turned off. The voltage should be kept between 2.0V~4.3V, Typical 3.0V. If VBACKUP power was not reserved, the GPS module will perform a lengthy cold start every time it is powered-on because previous satellite information is not retained and needs to be re-transmitted. <b>This pin must be connected for normal operation.</b>
5	3D_FIX	O	<b>3D-Fix Indicator</b> The 3D_FIX is assigned as a fix flag output. If not used, keep floating. <b>Before 2D Fix</b> The pin will continuously toggle with 1Hz. output one second high-level and one-second low-level signal <b>After 2D or 3D Fix</b> The pin will continuously output low-level signal. <b>This pin may not connected to high-level at power-on sequence.</b>
6	NC		Not connected
7	NC		Not connected
8	GND	P	Ground.
9	TX	O	<b>Serial Data Output A for NMEA output (TTL)</b> This is the UART transmitter of the module. It outputs GPS information for application.
10	RX	I	<b>Serial Data Input A for Firmware update (TTL)</b> This is the UART receiver of the module. It is used to receive commands from system.

11	EX_ANT	ANAI PO	External active antenna RF input. DC power from VCC and provide for external active antenna. DC power from VCC and provide for external active antenna (Recommendation: 3.3V). When a 4mA or higher current is detected, the detect circuit will acknowledge the external antenna as being present and uses external antenna for reception. In the event of short circuit occurring at external antenna, the module will limit the drawn current to a safe level. The 3.0V for the GPS external antenna is limited to 23mA. The 3.3V for the GPS external antenna is limited to 26mA. The 3.6V for the GPS external antenna is limited to 29mA.
12	GND	P	Ground .
13	1PPS	O	1PPS Time Mark Output 2.8V CMOS Level This pin provides one pulse-per-second output from the module and synchronizes to GPS time. Keep floating if not used.
14	RTCM	I	Serial Data Input for DGPS RTCM data streaming This pin receive DGPS data of RTCM protocol (TTL level). If not used keep floating.
15	NC		Not connected
16	NC		Not connected
17	NC		Not connected
18	NC		Not connected
19	GND	P	Ground
20	NC		Not connected

(1) I = INPUT; O = OUTPUT; I/O = BIDIRECTIONAL; P = POWER PIN; ANA = ANALOG PIN.



**9 PHYSICAL DIMENSIONS**

TOP VIEW

all units in mm, tolerance is  $\pm 0.2\text{mm}$

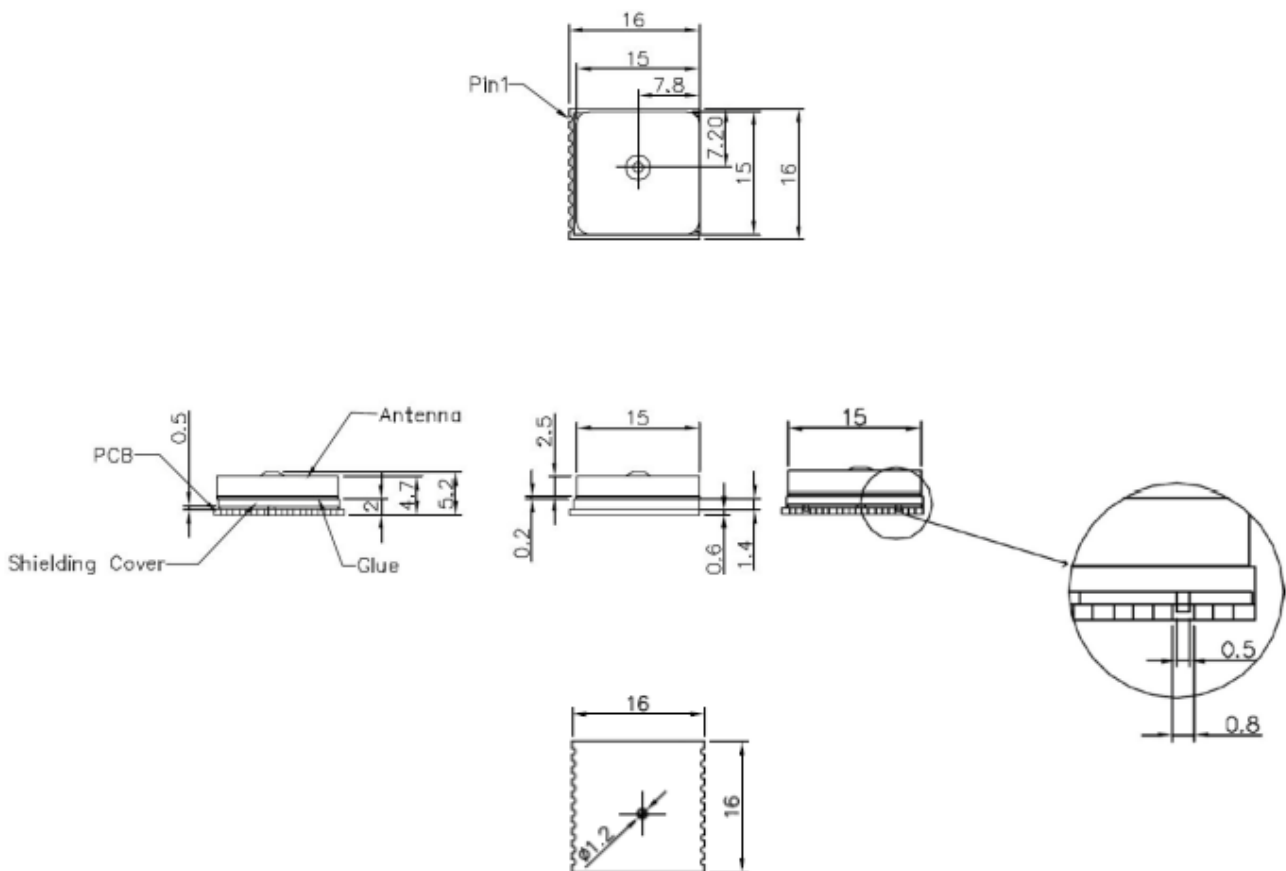

**10 RECOMMENDED PAD LAYOUT**

all units in mm. Tolerance: 0.1mm

**Footprint Top View**

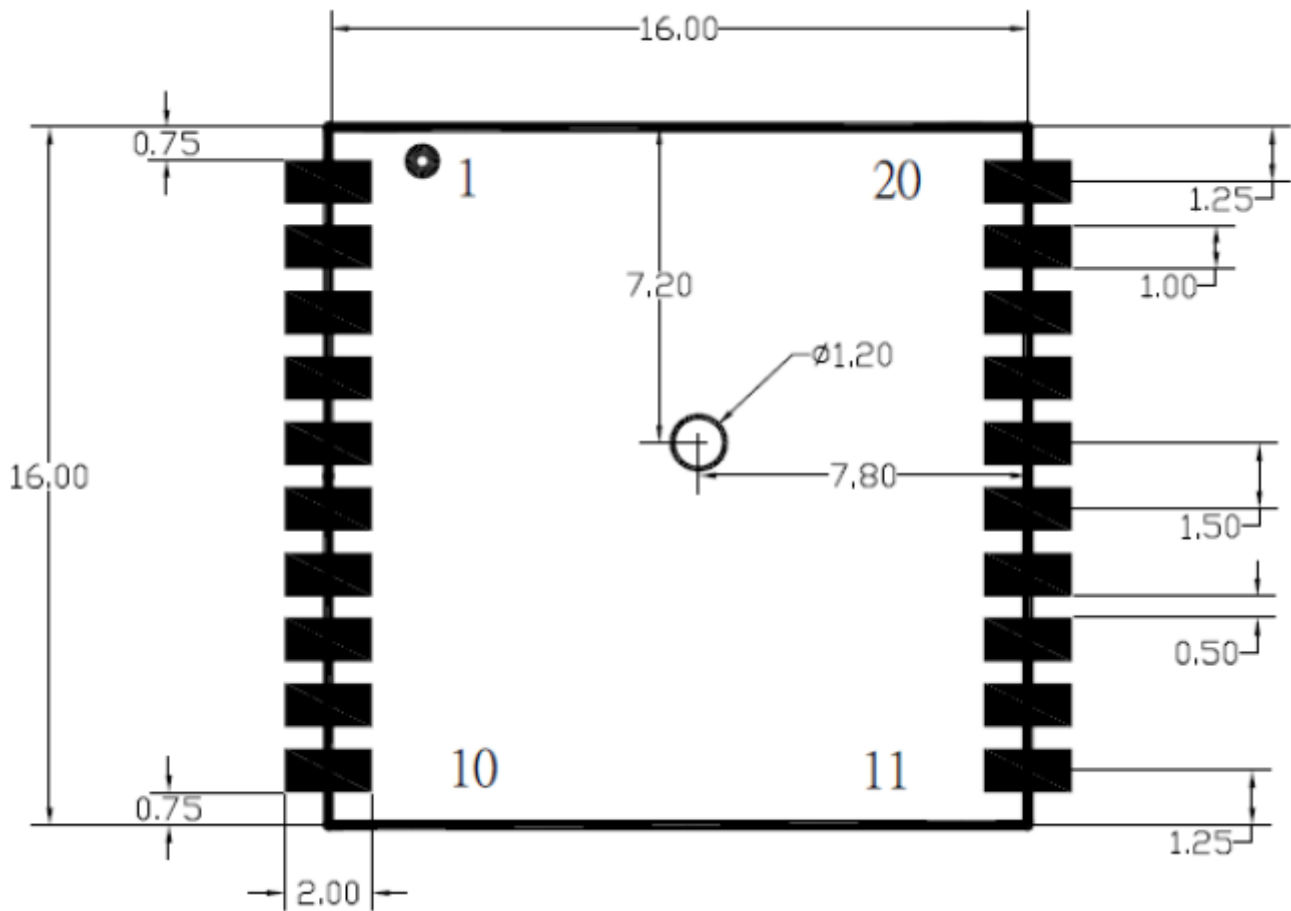

## 11 NMEA DATA interface

GNS603 provides NMEA (National Marine Electronics Association) 0183 compatible data. A set of proprietary NMEA commands are available to send control messages to the receiver. These commands are described in a separate document: *NMEACOMMANDInterface manual*. For standard operation, no commands are needed; the module will start outputting NMEA sentences after power supply has been attached. GNS603 will always start communication output with 9600 bit per second.

If non standard options are needed (f.e. other baud rate , other NMEA sequence) they can be programmed from host controller during runtime.

**Important note** : Options set by using NMEA command interface are not persistent! They will be lost when power is removed. A backup supply at VBACKUP will be sufficient to keep them.

### 11.1 NMEA output sentences

NMEA output sentences	
Type	content
Common GPS sentences	
\$GPRMC	Recommended Minimum Navigation Information
\$GPGGA	Fix Data, Time, Position and fix related data for a GPS receiver
\$GPGSA	DOP and active satellites
\$GPGLL	Geographic Position - Latitude/Longitude
\$GPVTG	Course and Speed Information relative to the Ground
\$GPGSV	GPS Satellites in view

### 11.2 NMEA command interface

GNS603 NMEA command interface allows to control settings and the extended functions. The command interface specification is available in an extra document: *NMEACOMMANDInterface manual*.

Two groups of commands are available:

Setting commands do modify the behavior of the module.

**Note** : Modified settings will be valid as long as the module is powered through VCC or VBACKUP. (f.e. : setting of a new baud rate). After removing VCC and VBACKUP, all settings are reset to their default values.

Action commands will perform the specified action one time after the command has been received. (f.e. : request for cold start)

Commands are always started with \$PTMK, directly followed by the command number 000..999. Each command must be terminated by \*<checksum>and a <CR><LF>.

The checksum calculation is simple, just XOR all the bytes between the \$ and the \* (not including the delimiters themselves). Then use the hexadecimal ASCII format.

## 12 MATERIAL INFORMATION

Complies to ROHS standard  
ROHS documentations are available on request  
Contact surface: gold over nickel

## 13 RECOMMENDED SOLDERING REFLOW PROFILE

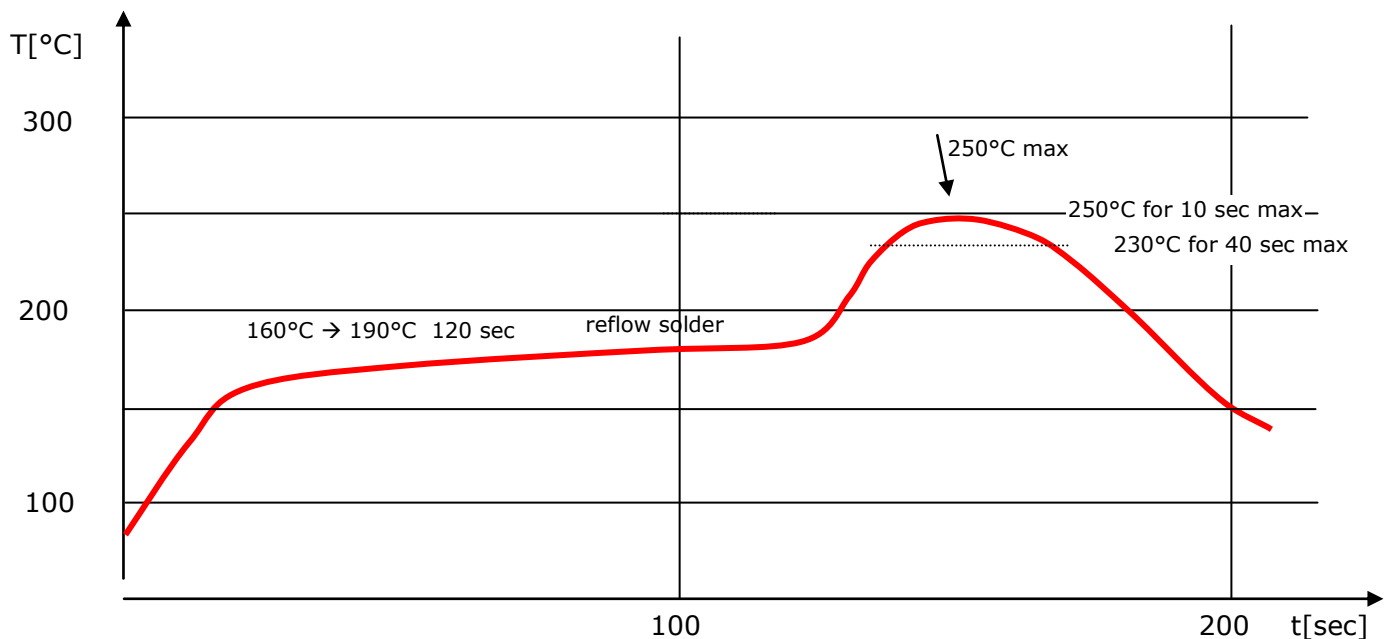

### Notes:

1. GNS603 should be soldered in upright soldering position. In case of head-over soldering, please prevent shielding / GNS603 receiver from falling down.
2. Do never exceed maximum peak temperature
3. Reflow cycles allowed : 1 time
4. Do not solder with Pb-Sn or other solder containing lead (Pb)
5. This device is not applicable for flow solder processing
6. This device is not applicable for solder iron process

## 14 TRAY PACKAGE INFORMATION

The GPS receivers are placed on a tray for quantities below 100 pieces. The trays will be stacked and packed together. The trays are placed inside an antistatic bag.



## 15 TAPE&REEL INFORMATION

Tape information:

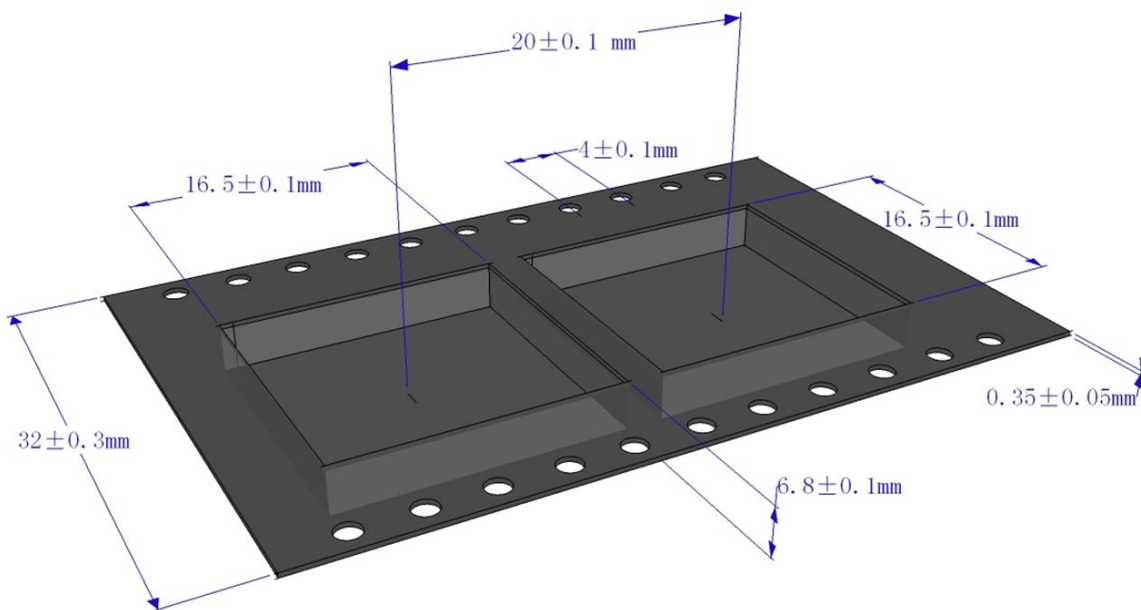

Reel information:

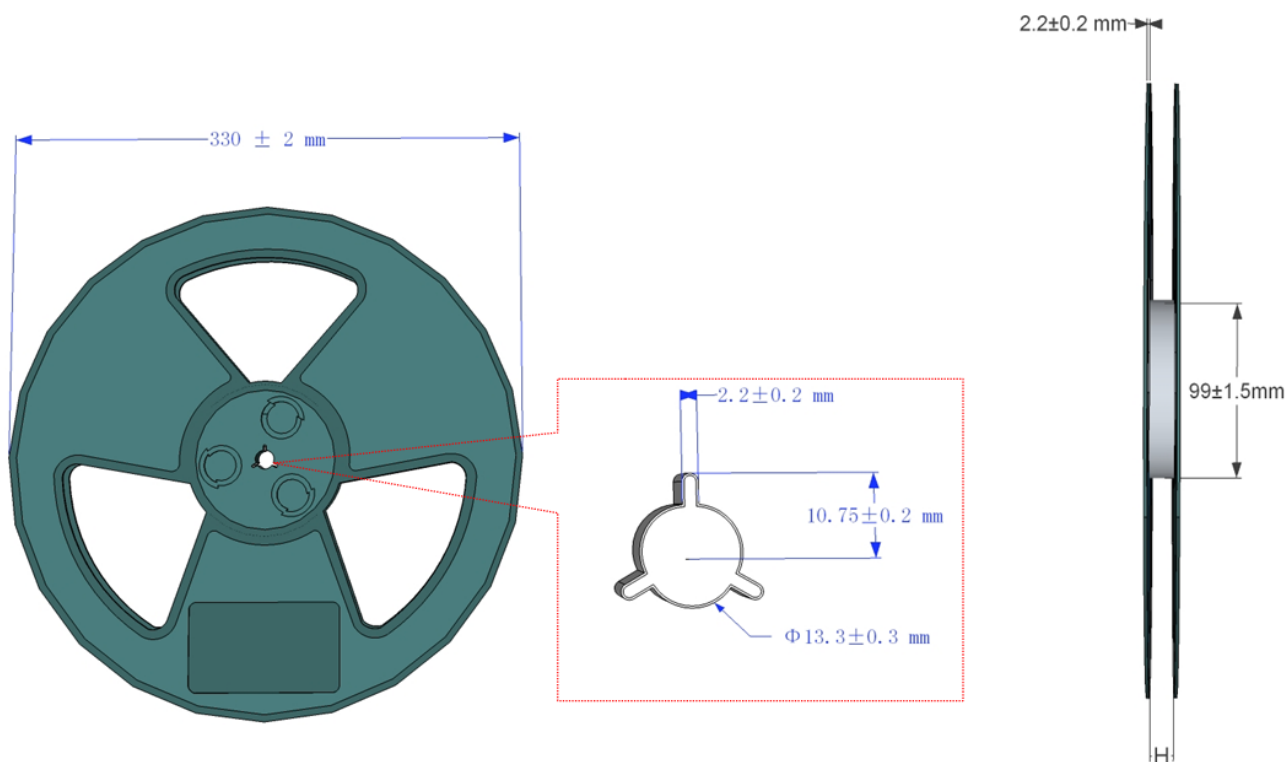

H= 32.5mm

Number of devices: 250pcs/reel

## 16 ORDERING INFORMATION

Ordering information			
Type	Part#	label marking	Description
GNS603	<b>4037735104945</b>	GNS603QYYWWSN	GNS603receiver YYWW => date code SN => serial number

## 17 FCC COMPLIANCE

This product has passed FCC 911 compliance successfully. The module emission and immunity has been proven to be compliant.

However, applications using this module as a component must pass CE and/or FCC again in whole.

## 18 ENVIRONMENTAL INFORMATION

This product is free of environmental hazardous substances and complies with 2002/95/EC. (RoHS directive).



## 19 MOISTURE SENSITIVITY

This device must be prebaked before being put to reflow solder process.

Disregarding may cause destructive effects like chip cracking, which leaves the device defective !

Shelf life	6 months , sealed
Possible prebake recommendations	12 hrs @ 60°C
Floor life (time from prebake to solder process)	<72 hrs

## 20 DOCUMENT REVISION HISTORY

V1.0	May 24 2013	M.Reiff	initial document

21 RELATED DOCUMENTS

<b>Title</b>	<b>Description / file</b>	<b>Available from</b>
<i>NMEAcommandInterface manual</i>	Detailed description of NMEA commands	<a href="http://www.forum.gns-gmbh.com">www.forum.gns-gmbh.com</a>
<i>NMEA protocol</i>	Detailed description of NMEA protocol	<a href="http://www.forum.gns-gmbh.com">www.forum.gns-gmbh.com</a>