



### 1 INTRODUCTION

GNS701 is a small autonomous GPS/GLONASS/GALILEO receiver, based upon the MediaTek MT3333 single chip, available with a finely tuned, high-sensitivity patch ceramic antenna. The receiver supports GPS and GLONASS and GALILEO simultaneously.

The navigation performance and accuracy is further improved by using correction data from SBAS (WAAS, EGNOS, GAGAN, MSAS), QZSS or DGPS(RTCM).

First Fixes after just a few seconds are achieved with the help of A-GPS using EPO™ (Extended Prediction Orbit) and the EASY™ "self generated orbit prediction" algorithm. EASY™ (Embedded Assist System) does not require any resources or assist data from the host.

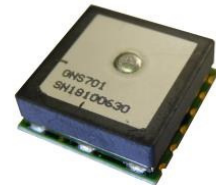

The excellent low power design makes it easy to implement this receiver in power sensitive, battery supplied applications. The new AlwaysLocate™ power management feature will improve this behaviour additionally. It adaptively adjusts power consumption depending on the environment and motion conditions, in order to achieve a balance between fix rate, power consumption and position accuracy. Very low power requirements (typ 66mW@ 3.3V, tracking for GPS+GLONASS) and internal voltage regulator makes it easy to run the receiver with various power supplies and allows direct connection to LiIon batteries.

GNS701 offers the industry's highest level of navigation sensitivity up to -165dBm<sup>1</sup>. It has superior dynamic performance at high velocity and provides effective protection against interference signals using MTAIC™ ( Multi-tone active interference canceller). Up to 12 independent channel interference continuous wave jammers <-80dBm can be eliminated or reduced.

The embedded logger function LOCUS with a 16-hrs on chip memory makes this GPS module a complete track logger for many applications. With AlwaysLocate™ data logging can be achieved up to 32-hrs under standard conditions.

In professional timing applications the outstanding high accuracy PPS (pulse per second) hardware pin is used for synchronization to GPS second. Typical accuracy is 10ns.

<sup>1</sup> note: Based on chip specifications

### Features

- GLONASS and GPS and GALILEO simultaneously
- 99 acquisition-/ 33 tracking channels
- Ultra high tracking/navigation sensitivity: -165dBm<sup>1</sup>
- Smart antenna: finely tuned 18x18x4mm ceramic antenna
- SBAS (WAAS, EGNOS, MSAS, GAGAN, QZSS) correction support
- A-GPS by EPO "Extended Prediction Orbit"<sup>TM</sup> enables 7/14days prediction
- 12 Multitone Active Interference Canceller (MTAIC) for GPS-in-band jammer rejection
- EASY<sup>TM</sup> : Self generated orbit prediction support
- AlwaysLocate<sup>TM</sup> : Intelligent Algorithm for power saving
- High accuracy 1PPS output
- NMEA-0183 or binary protocol
- High update rate (up to 10/s)
- Embedded logger function with 16hrs internal memory
- GPS current consumption (@3.3V):
  - Acquisition: 35mA Typical
  - Tracking: 22mA Typical
- Low backup current consumption 15uA, typical
- SMD type with stamp holes
- Small form factor: 19.5x19.5x7.2mm
- CE, FCC and RohS certified

<sup>1</sup> note: Based on chip specifications

### 2 INDEX

1 INTRODUCTION -----	1
2 INDEX -----	3
3 FUNCTIONAL DESCRIPTION -----	4
3.1 System description -----	4
3.2 Block diagram -----	4
3.3 GPS and GLONASS AND GALILEO simultaneous operation -----	5
3.4 Power Management Features -----	5
3.5 Logger function -----	7
3.6 Active interference cancellation (MTAIC) -----	7
3.7 AGPS with EPO data -----	7
3.8 EASY™ self generated prediction data feature -----	8
3.9 Pulse Per Second (PPS) -----	9
3.10 SBAS (Satellite Based Augmentation) support -----	9
3.11 DGPS (Differential GPS) support -----	9
3.12 Single sentence output -----	10
3.13 Last position retention -----	10
3.14 Geofencing function -----	10
3.15 Magnetic variation feature -----	10
3.16 Distance calculation feature -----	10
3.17 GPS/GLONASS almanac and ephemeris data -----	10
3.18 Real time clock (RTC) -----	10
3.19 UART interface -----	11
3.20 Module default settings -----	11
4 TYPICAL APPLICATION BLOCK DIAGRAM -----	12
4.1 Typical System Overview -----	12
5 GPS/GLONASS characteristics -----	13
5.1 GPS/GLONASS characteristics -----	13
6 DESIGN GUIDELINES -----	14
7 ELECTRICAL SPECIFICATION -----	14
7.1 Absolute Maximum Ratings -----	14
7.2 Recommended Operating Conditions -----	14
8 PIN CONFIGURATION -----	15
9 PHYSICAL DIMENSIONS -----	16
10 RECOMMENDED PAD LAYOUT -----	17
11 NMEA DATA interface -----	18
11.1 NMEA output sentences -----	18
11.2 NMEA command interface -----	19
12 MATERIAL INFORMATION -----	19
13 RECOMMENDED SOLDERING REFLOW PROFILE -----	20
14 TRAY PACKAGE INFORMATION -----	21
15 TAPE&REEL INFORMATION -----	21
16 ORDERING INFORMATION -----	22
17 FCC COMPLIANCE -----	23
18 Quality and Environmental Specifications -----	23
19 DOCUMENT REVISION HISTORY -----	24
20 RELATED DOCUMENTS -----	25

### 3 FUNCTIONAL DESCRIPTION

#### 3.1 System description

The GNS701 is a high performance, low power GPS/GLONASS/GALILEO receiver that includes an integrated RF frontend (SAW Filter + LNA) and a finely tuned 18x18x4mm ceramic patch antenna. Due to high input sensitivity and integrated low noise amplifier (LNA), it can work at very weak GPS/GLONASS signals.

GNS701 is a complete autonomous GPS/GLONASS/GALILEO receiver, including:

- Full GPS/GLONASS/GALILEO processing, without any host processing requirements
- Standard NMEA message output
- A powerful NMEA command and control interface
- All clock sources integrated
- RF frontend integrates a low noise amplifier (LNA) and a SAW filter
- Rich additional features like geofencing, single sentence output, last position retention, magnetic variation, distance calculation
- Interface for UART, PPS output pin, Fix Status Indicator pin

#### 3.2 Block diagram

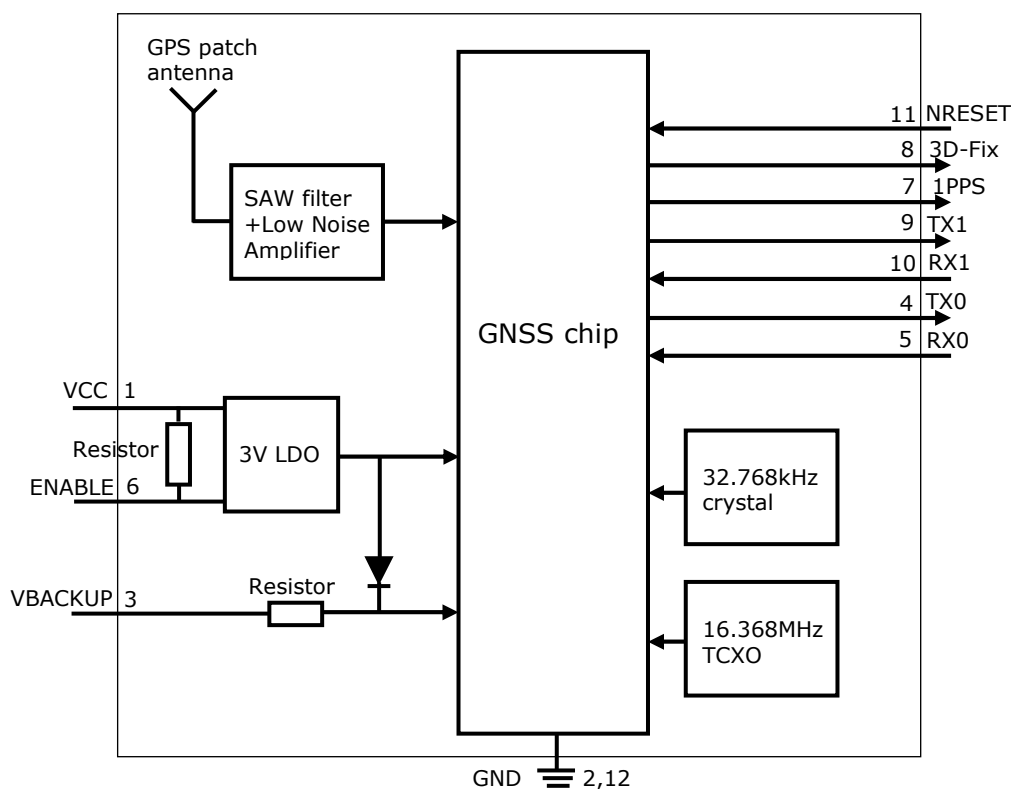

### 3.3 GPS and GLONASS AND GALILEO simultaneous operation

GNS701 supports tracking of GPS and GLONASS and GALILEO satellite system at one time. This feature enhances the overall performance significant.

- Increased availability of number of satellites
- Increased spatial distribution allows better geometrical conditions
- Reduced Horizontal (HDOP) and Vertical Dilution of Precision (VDOP) factors

In GPS-only operation, a minimum of 3 SVs is needed to determine a 2D position fix solution. When using both systems, 5 SVs are needed to determine the four unknowns and one more SV to calculate the GPS/GLONASS time offset.

Using a combined receiver, users have an access to potentially 48 or more satellites. This high number of satellites can overcome the typical problems of restricted visibility of the sky, such as in urban canyons or indoor scenarios.

### 3.4 Power Management Features

Power management schemes implemented for any GPS system requires an optimally tuned performance for both accuracy of the position fixes and the average power consumed for best user experience. GNS701 architecture achieves these both aspects by providing flexibility and design choices for the system integration, based on wide range of use cases and by leveraging on the proven silicon methodologies. Also GNS701 provides position, velocity and time measurements without any host loading. This, coupled with the optional built-in power management options, reduces the overall system power budget.

Selectable Power management features:

- In **Standby mode** RF frontend and internal MPU are switched to deep sleep state. Power consumption is reduced. This state can be entered by sending the NMEA command: `$PMTK161,0*28<CR><LF>`. Leaving standby mode and resuming to normal operation will be managed by sending any byte to the module.

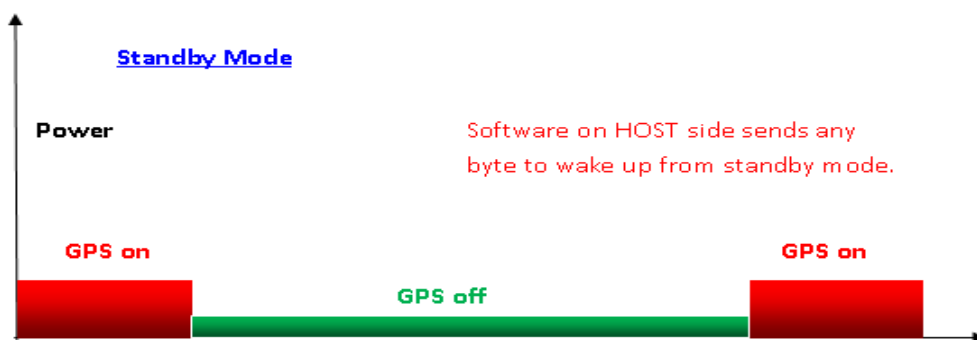

- **Backup mode** can be entered by sending NMEA command: \$PMTK225,4\*2F<CR><LF>. The GPS core will shut down autonomously to backup state, Vcc supply can now be switched off by an external power supply switch.
- **Periodic mode** describes a power mode, which will autonomously power on/off the module in programmable time slots with reduced fix rate. Periodic mode is useful during stationary operation or if position fixes are just needed from time to time. Since power consumption in **GPS off** times is nearly zero, the power consumption in periodic mode can be estimated by  $P_{\text{tracking}} * (t_{\text{on}} / (t_{\text{on}} + t_{\text{off}}))$ . Periodic mode is controlled with NMEA command \$PMTK225. See document *GPS/GLONASS\_NMEAcommandInterface manual* for programming details.

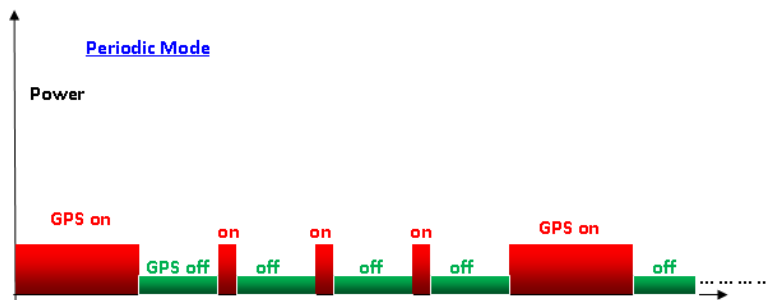

- **AlwaysLocate™** feature provides an optimized overall GPS/GLONASS system power consumption in tracking mode under open sky conditions. Always Locate is an intelligent control of periodic mode. Depending on the environment and motion conditions, GNS701 can adjust the on/off time to achieve balance of positioning accuracy and power consumption. The best power saving will be made under good reception in stationary mode. Critical reception conditions and dynamic movements will need full activity of the GNSS engine which causes nominal power requirements (29mA typ in tracking mode).

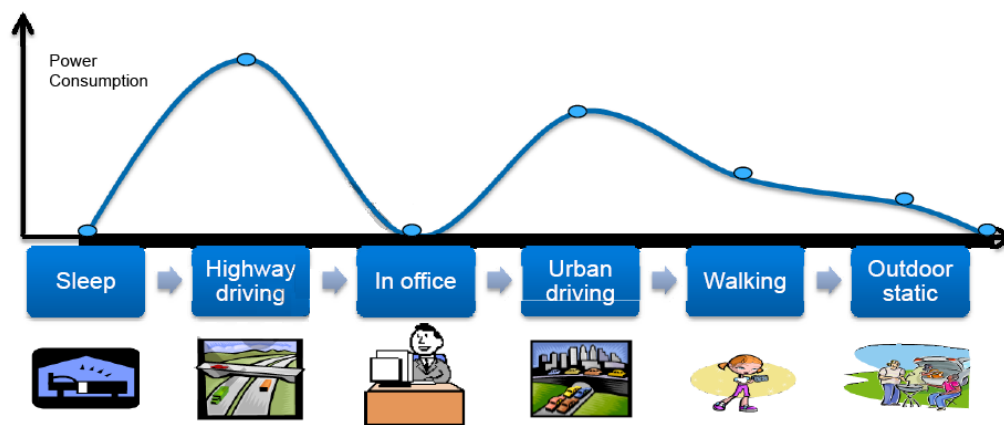

### 3.5 Logger function

GNS701 provides an autonomous logger function that automatically stores position information in an internal 128kB flash memory. A complete tracking unit can be realized without any external CPU or memory.

The parameters for logging are programmable via the NMEA command interface. The following parameter can be set to optimize logging time:

- logger rate

The commands for logger include:

- start logging
- stop logging
- erase memory
- readout memory

please refer to the *GPS/GLONASS\_NMEAcommandInterface manual* for details.

Internal Logger Function					
Logger data rate	1/15		1	1/s	
Logger data memory		128		kBytes	Flash memory
Logger trigger		programmable			Logger can be triggered on various events

### 3.6 Active interference cancellation (MTAIC)

Because different wireless technologies like Wi-Fi, GSM/GPRS, 3G/4G, Bluetooth are integrated into portable systems, the harmonic of RF signals may influence the GPS reception.

The multi-tone active interference canceller can reject external RF interference which come from other active components on the main board, thus improving the performance of GPS reception.

GNS701 can cancel up to 12 independent continuous wave (CW) channels having signal levels of up to -80dBm. The functionality is enabled by default and increases power consumption by about 1mA.

### 3.7 AGPS with EPO data

AGPS (assisted GPS) allows to shorten TTFF (TimeToFirstFix) by injecting ephemeris data from an external source into the module's memory. With the help of these data, the module does not need to acquire satellite positions by receiving the data from the satellites.

Depending on time and position information, that is still available in the module memory, the TTFF can be reduced to just a few seconds.

The GNS AGPS service is based on a short term predicted data service. The predicted data will be fully processed by the GPS engine. The host must load the data from the web and transfer them over the UART into the module:

1. Check GNS701 module EPO (Extended Prediction Orbit) data for validity by comparing the time.

*preliminary specification*

2. Connect to web server through network connection (GPRS, WLAN, LAN,..).
3. Download file. There are just two files, covering all GPS satellites. The first file (MTK7d.EPO) is for 7 days (53kB), the other is 106Kbytes for 14 days (MTK14d.EPO)
4. "Parse" file, using software example. This is quite easy, there must be added some header bytes and a checksum and a control counter. GNS offers software support on this.
5. Download to GNS701 receiver. Please refer to the *GPS/GLONASS\_NMEAcommandInterface manual* for details.

If the host has low memory available, there's no need to save the whole file. The steps 3..5 can be done frame by frame needing less than 2kBytes of buffer memory.

Code samples and support for several platforms are available from GNS (in preparation). Thanks to the predicted system, download data stay valid for up to 14 days. Therefore, users can initiate the download everytime and benefit from using (W)LAN instead of using expensive GSM. File size will be ~50kBytes for a one week prediction data set.

AGPS characteristics					
System					6hrs predicted data
File size for data download		53		kB	1 week prediction data
Maximum prediction time	7	14		days	
TTFF		1		sec	Time and last position available
TTFF		15		sec	Last position available

### 3.8 EASY™ self generated prediction data feature

GNS701 includes an internal prediction system, that allows to sample satellite orbit data during operation and use that data to speed up TTFF on later starts. The prediction time frame is up to three days forward.

Although this prediction feature does not provide the very short TTFF that is achieved using AGPS, it can help to find a fix solution faster and in weak signal condition scenario. Prediction data will be kept in memory as long as VBACKUP is present. This option is activated by default.

**Note:** The EASY functionality is only supported, if "VBACKUP" pin is connected and the NMEA update rate is 1Hz.

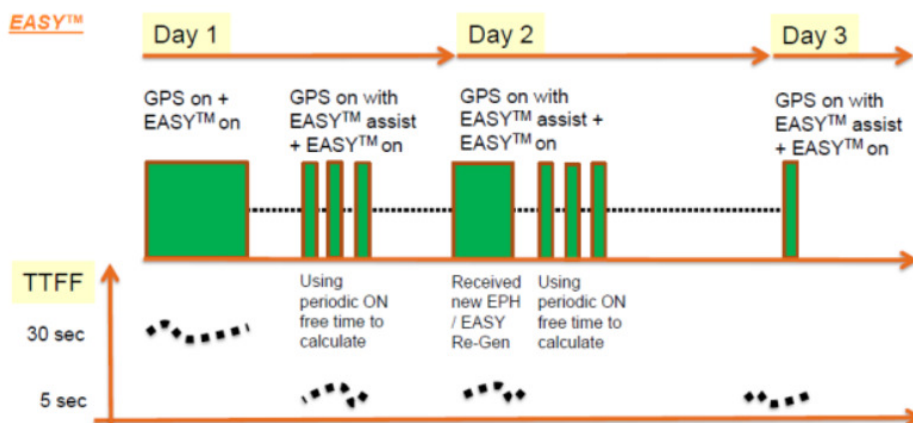



### 3.9 Pulse Per Second (PPS)

GNS701 provides a Pulse Per Second (PPS) hardware output pin for timing purposes. After calculation of a 3D position fix (default setting), the PPS signal is accurately aligned to the GPS second boundaries. The pulse generated is approximately 100 milliseconds in duration and the repetition rate is 1 second. On request PPS output can be activated on a 2D-fix or after power-up of the module, providing a time accuracy decreased PPS signal.

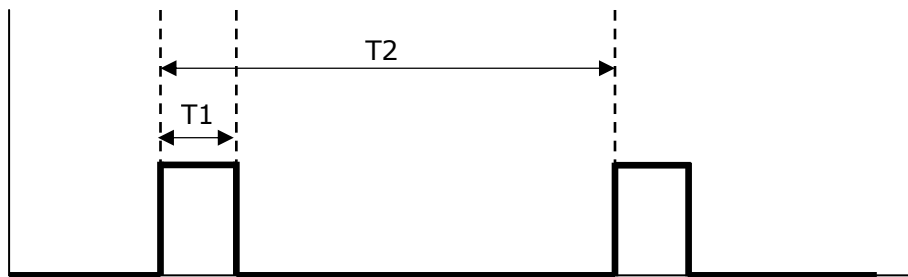

$$T1 = 100\text{ms} \quad T2 = 1\text{sec}$$

GNS701 module provides an exceptionally low RMS jitter of typical 10 nanoseconds.

PPS characteristics based upon a 3D-fix					
1PPS pulse duration	-	100	-	msec	
1PPS time jitter	-	10		nsec RMS	Pulse rising edge deviation from expected pulse time, measured with full 3D fix
1PPS rise and fall time		5		nsec	10%..90%, load is 10k  5pF

### 3.10 SBAS (Satellite Based Augmentation) support

GNS701 supports Satellite Based Augmentation for improvement of the navigation precision. Correction data is sent from geostationary satellites to the GPS/GLONASS receiver. GNS701 supports European, US, and Asian augmentation systems (EGNOS, WAAS, GAGAN, MSAS, QZSS) to enable precision improvements in nearly every region of the world.

SBAS is active by default and will automatically track the available SBAS satellites. It can be disabled by NMEA command. See document *GPS/GLONASS\_NMEAcommandInterface manual* for details

**Note :** In SBAS mode, the maximum NMEA sentence update rate is limited to 5 per second.

### 3.11 DGPS (Differential GPS) support

GNS701 accepts DGPS input in RTCM format. DGPS provides precision position fixes down to centimetres and is used in professional applications like agriculture. The second UART (UART\_1) of the module is used to feed the data in. DGPS is deactivated by default. For configuration of the UART port, some NMEA commands must be implemented. See *GPS/GLONASS\_NMEAcommandInterface* document for details.

**Note** : Since SBAS and DGPS both do (different) corrections on the fix position solution, they cannot be used at the same time! SBAS / DGPS usage is programmed through the NMEA Interface.

### 3.12 Single sentence output

GNS701 allows to reduce data transfer to host to a minimum. Reduced data transfer can save host processor activity times and thus reduce system power consumption. All relevant information will be provided in a single sentence output. To save further channel load, the sentence can be formatted as binary. Need of firmware customization.

### 3.13 Last position retention

Depending on the application, it might be useful to retain the last position or to clear the position when having no fix solution. Last position retention can be enabled or disabled. When enabled, the last known position is outputted in the NMEA sentences. Need of firmware customization.

### 3.14 Geofencing function

GNS701 has an internal algorithm to determine whether the actual position is within a circular area around a predefined location point. A proprietary sentence indicates the "inside" or "outside" status. Need of firmware customization.

### 3.15 Magnetic variation feature

As the magnetic variation feature is enabled, data output provides informations about the degree of magnetic variation and the measured magnetic heading. Need of firmware customization.

### 3.16 Distance calculation feature

This feature allows to request the real "line of sight" distance in relation to a predefined position. This feature can remove some load from the host processor. Need of firmware customization.

### 3.17 GPS/GLONASS almanac and ephemeris data

For quick re-acquisition of the GPS/GLONASS receiver after off-times, the GPS/GLONASS engine should have access to almanac and ephemeris data. This data is permanently stored inside GNS701 module, even if all power supplies have been removed. When the receiver is powered-up again, the data will be used to allow a quick re-acquisition, as soon as a coarse time information is available. Time will be available immediately, when RTC is kept running.

### 3.18 Real time clock (RTC)

GNS701 has a real time clock with 32,768Hz crystal on board. As long as VBACKUP is connected to a power source, the real time clock and the module memory can be kept alive at very low power consumption of just 15uA. The RTC will track the current time and enable the module to start from sleep states with very fast time to first Fix (TTFF).

### 3.19 UART interface

GNS701 core and I/O sections work at 3.3V nominal. Absolute Maximum Ratings should not be exceeded. Should the GNS701 be interfaced to a host with I/O at higher/lower levels, level shifters should be used. UART baud rate is 9600baud by default. The baud rate can be modified to higher rates by a NMEA software command. See document *GPS/GLONASS\_NMEAcommandInterface manual* for details.

UART Default Settings	
Parameter	Value
Baud rate	9600
Data length	8 bits
Stop bit	1
Parity	None

### 3.20 Module default settings

The GNS701 receiver comes with default settings, which are persistently programmed. Whenever power is removed from the module (both VCC and VBACKUP), the settings will be reset to the values shown in the following table.

Default settings	
Setting	Default value
UART setting	9600,8,N,1
Fix frequency (update rate)	1/sec
NMEA sentences	Refer to chapter 11.1 "NMEA output sentences"
NMEA rate	Once a second: RMC,GSA,VTG,GGA every 5 sec :GSV sentences
Self survey prediction mode: EASY™	enabled
Active interference cancellation:MTAIC	enabled
DGPS option	SBAS enabled
Datum	WGS 84
Logging parameters	Full&Stop / Content Basic / Interval 15 sec
Single sentence output	Customized firmware needed
Last position retention	Customized firmware needed
Magnetic variation	Customized firmware needed
Geofencing function	Customized firmware needed
Distance calculation	Customized firmware needed

On request, other options can be selected as preprogrammed (persistent default) options.

Please contact the GNS support for your project requirements.

Note : Customized options are solely available for fixed order lots.

### 4 TYPICAL APPLICATION BLOCK DIAGRAM

#### 4.1 Typical System Overview

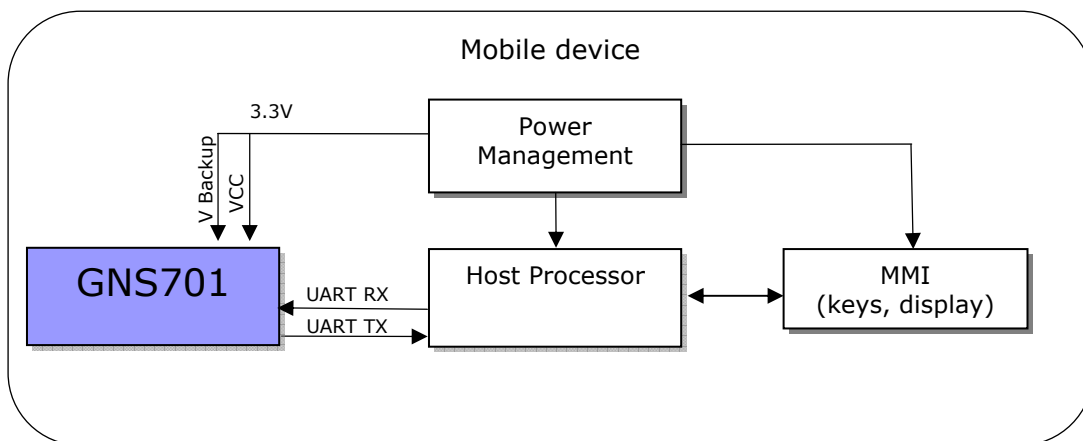

### 5 GPS/GLONASS characteristics

5.1 GPS/GLONASS characteristics					
Parameter	Min	Typ	Max	Unit	Note
general					
Frequency		1575.42		MHz	GPS L1
		1598.0625~ 1609.3125		MHz	GLONASS L1
		1559 - 1591		MHz	GALILEO L1
Datum					WGS84
AGPS	7		14	days	Configurable
Output data frequency	1/10	1	10	1/sec	
Navigation&tracking sensitivity <sup>1</sup>		-165		dBm	autonomous
Acquisition sensitivity <sup>1</sup>		-148		dBm	Cold start
Reacquisition sensitivity <sup>1</sup>		-163		dBm	Hot start
TTF hotstart <sup>1</sup>		1		sec	All SVs @-130dBm
TTF autonomous warm start <sup>1</sup>		34		sec	All SVs @-130dBm
TTF autonomous cold start <sup>1</sup>		35		sec	All SVs @-130dBm
Reacquisition time <sup>1</sup>		<1		sec	All SVs @-130dBm
Number of channels tracking		33			
Number of acquisition channels		99			
Dimension		19.5x19.5x7.2		mm	Tolerance is +/-0.2 mm
Weight		8		g	
Power consumption					
GPS ACTIVE (acquisition)		35		mA	NMEA frequency = 1/sec, 3.3V, SBAS enabled, MTAIC enabled
GPS ACTIVE (tracking)		22		mA	NMEA frequency = 1/sec, 3.3V, SBAS enabled, MTAIC enabled
Backup current @ 3V		15		uA	
Accuracy					
Position error (50%CEP)	-	3	-	m	Without aid 2D-RMS
Position error (50%CEP)	-	2.5	-	m	Using (SBAS) 2D-RMS
Velocity error	-	0.1	-	m/s	Without aid
Velocity error	-	0.05	-	m/s	Using (SBAS)
ITAR limits					
Operation altitude		-	18,000	m	
Operation velocity	-	-	515	m/s	
Operation acceleration	-	-	4	G	

<sup>1</sup> note: based on chip specifications

### 6 DESIGN GUIDELINES

Although GNS701 GPS/GLONASS receiver provides best performance at low power consumption. Special care should be taken to provide clean signal and clean power supplies. Power lines should be blocked near to the receiver with low ESR capacitors.

Radiated noise from neighbour components may also reduce the performance of the receiver. Please refer to "GNS701 Starter Kit User Manual" for more informations, downloadable at the GNS forum: [www.forum.gns-gmbh.com](http://www.forum.gns-gmbh.com).

### 7 ELECTRICAL SPECIFICATION

7.1 Absolute Maximum Ratings		
Parameter	Value	Unit
Supply voltage range: Vcc	3.0 to 4.3	V
Backup voltage: VBACKUP	2 to 4.3	V

7.2 Recommended Operating Conditions					
Parameter	Min	Typ	Max	Unit	Note
V <sub>cc</sub>	3.0	3.3	4.3	V	supply voltage
V <sub>cc</sub> ripple voltage				50	mVpp
VBACKUP	2.0	3.0	4.3	V	Backup voltage for RTC and memory retention, must be available during normal operation
RX0 TTL H Level	2.0		V <sub>cc</sub>	V	Condition: VCC=3.0V~4.3V
RX0 TTL L Level	0		0.8	V	Condition: VCC=3.0V~4.3V
TX0 TTL H Level	2.4		2.8	V	Condition: VCC=3.0V~4.3V
TX0 TTL L Level	0		0.4	V	Condition: VCC=3.0V~4.3V
Storage temperature	-50		90	°C	
Operating temperature	-40		85	°C	

### 8 PIN CONFIGURATION

#### Top View

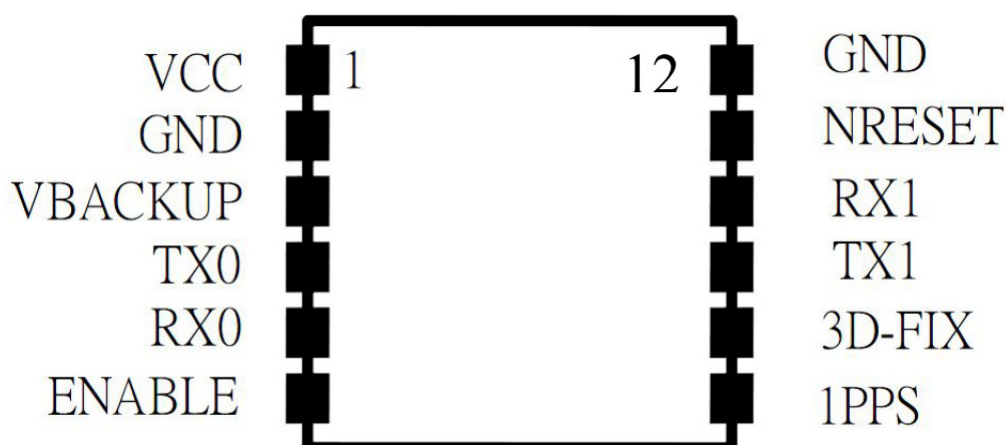

Pin	Name	I/O	Description & Note
1	VCC	P	Main DC power input The main DC power supply for the module. The voltage should be kept between from 3.2V to 5.0V. The ripple must be limited under 50mVpp (Typical: 3.3V).
2	GND	P	Ground
3	VBACKUP	P	Backup power input for RTC & navigation data keep This connects to the backup power of the GPS module. Power source (such as battery) connected to this pin will help the GPS chipset in keeping its internal RTC running when the main power source is turned off. The voltage should be kept between 2.0V~4.3V, Typical 3.0V. If VBACKUP power was not reserved, the GPS receiver will perform a lengthy cold start every time it is powered-on because previous satellite information is not retained and needs to be re-transmitted.
4	TX0	O	Serial Data Output A for NMEA output (TTL) This is the UART-A transmitter of the module. It outputs GPS information for application.
5	RX0	I	Serial Data Input A for Firmware update (TTL) This is the UART-A receiver of the module. It is used to receive commands from system
6	ENABLE	I	High active, or keep floating for normal working Enable (High): $1.8 \leq V_{enable} \leq V_{CC}$ Disable (Low): $0V \leq V_{enable} \leq 0.25V$
7	1PPS	O	1PPS Time Mark Output 2.8V CMOS Level This pin provides one pulse-per-second output from the module and synchronizes to GPS time. Keep floating if not used.
8	3D_FIX	O	3D-Fix Indicator The 3D_FIX is assigned as a fix flag output. If not used, keep floating. <b>Before 2D Fix</b> The pin will continuously toggle with 1Hz. output one second high-level and one-second low-level signal <b>After 2D or 3D Fix</b> The pin will continuously output low-level signal. <b>This pin may not connected to high-level at power-on sequence.</b>
9	TX1	O	Serial Data Output A for NMEA output (TTL) This is the UART transmitter of the module. It outputs GPS information for application. If not used, keep floating.
10	RX1	I	Serial Data Input A for Firmware update (TTL) This is the UART receiver of the module. It is used to receive commands from system. If not used, keep floating.
11	NRESET	I	Reset Input, Low Active Low active, it causes the module to reset. If not used, keep floating.
12	GND	P	Ground

(1) I = INPUT; O = OUTPUT; I/O = BIDIRECTIONAL; P = POWER PIN; ANA = ANALOG PIN.

### 9 PHYSICAL DIMENSIONS

#### TOP VIEW

all units in mm, tolerance is  $\pm 0.2\text{mm}$

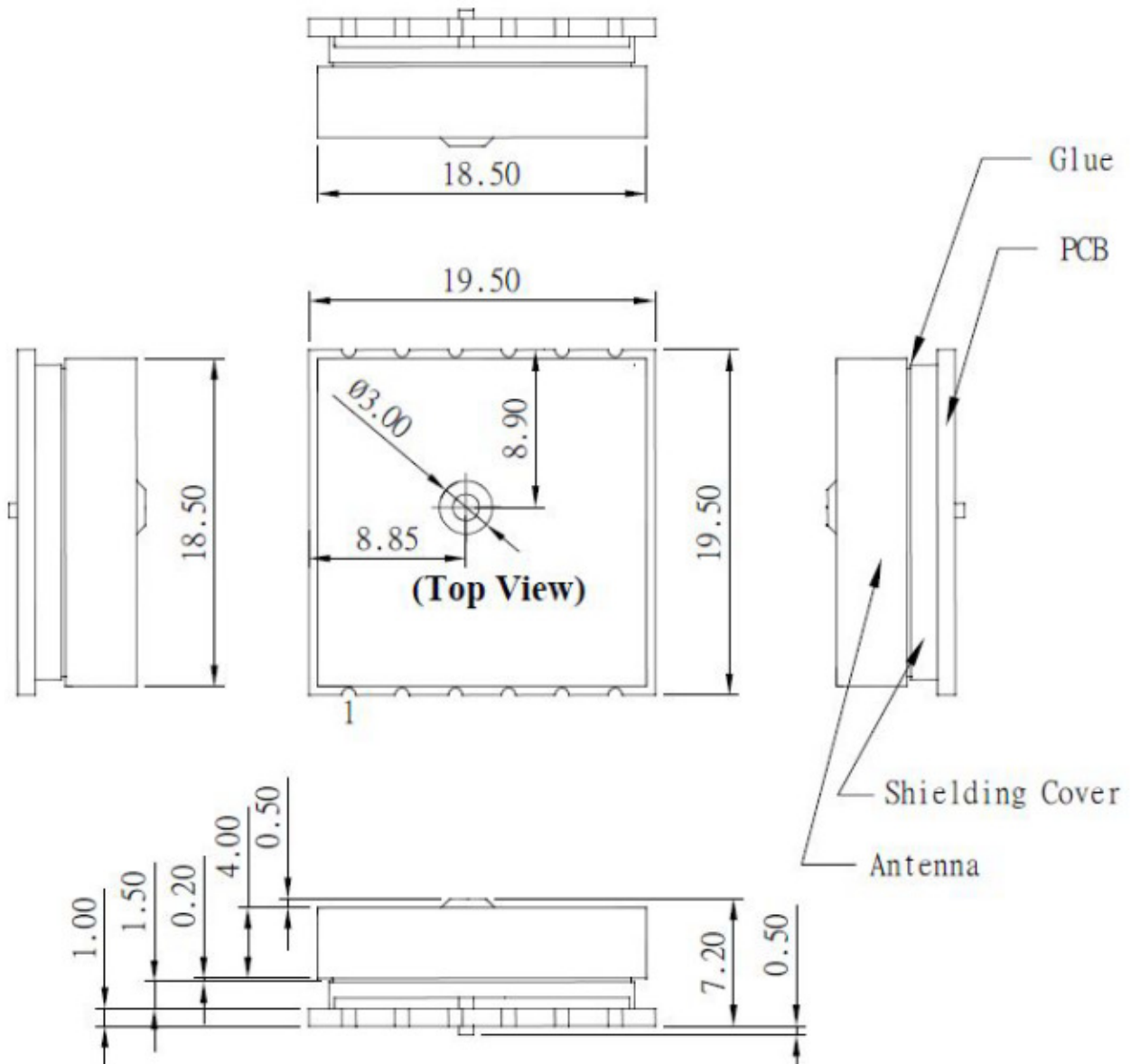



### 10 RECOMMENDED PAD LAYOUT

all units in mm

#### Footprint Top View

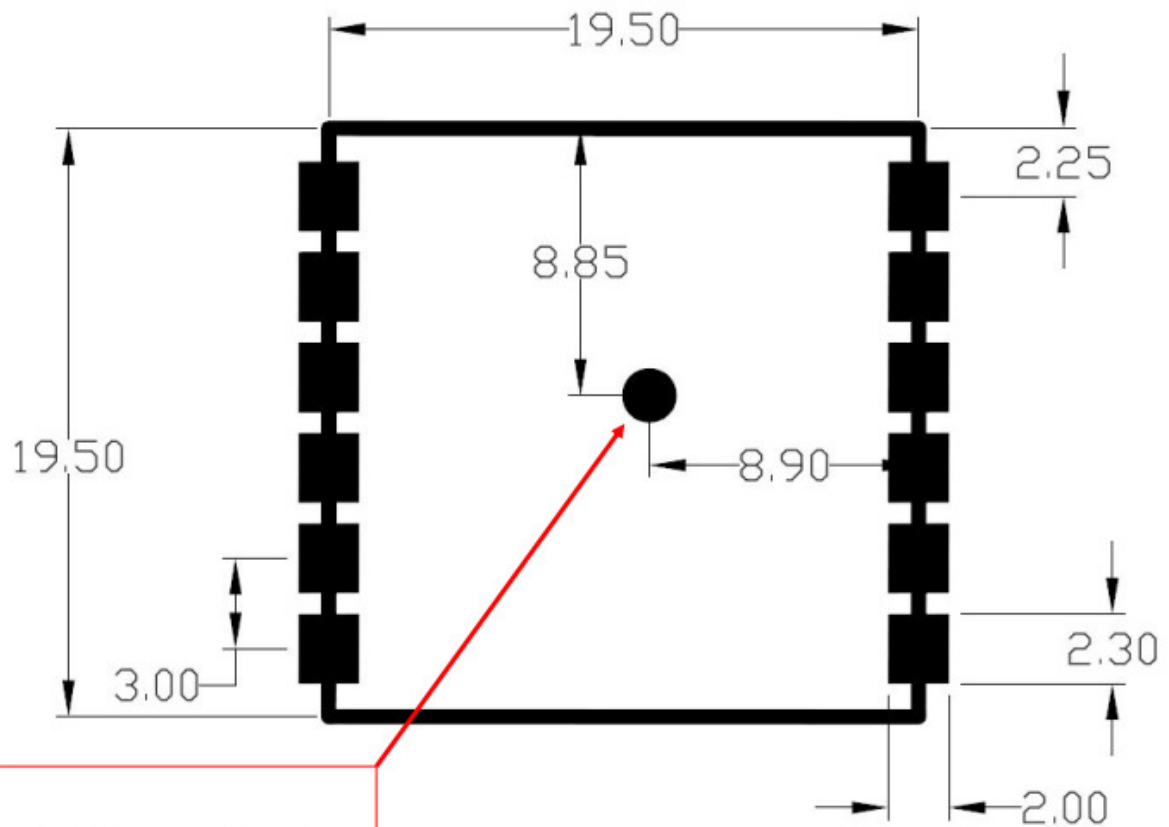

**Note.**

Place one hole (diameter =3.0mm)  
under this module for the antenna pad.

### 11 NMEA DATA interface

GNS701 provides NMEA (National Marine Electronics Association) 0183 compatible data. A set of proprietary NMEA commands are available to send control messages to the receiver. These commands are described in a separate document: *GPS/GLONASS\_NMEAcommandInterface manual*.

For standard operation, no commands are needed; the module will start outputting NMEA sentences after power supply has been attached. GNS701 will always start communication output with 9600 bit per second.

If non standard options are needed (f.e. other baud rate , other NMEA sequence) they can be programmed from host controller during runtime.

**Important note** : Options set by using NMEA command interface are not persistent! They will be lost when power is removed. A backup supply at VBACKUP will be sufficient to keep them.

#### 11.1 NMEA output sentences

NMEA output sentences	
Type	content
RMC	Recommended Minimum Navigation Information
GGA	Fix Data, Time, Position and fix related data
GLL	Geographic Position - Latitude/Longitude
GSA	DOP and active satellites
VTG	Course and Speed Information relative to the Ground
GSV	Satellites in view

NMEA output sentences identifier, related to its GNSS system:

NMEA output identifier					
System	GGA	GSA	GSV	RMC	VTG
<b>GPS</b>	GPGGA	GPGSA	GPGSV	GPRMC	GPVTG
<b>GPS+GLONASS</b>	GNGGA	GPGSA GLGSA	GPGSV GLGSV	GPRMC <sup>1</sup> or GNRMC	GNVTG
<b>GPS+GLONASS +GALILEO</b>	GNGGA	GPGSA GLGSA GAGSA	GPGSV GLGSV GAGSV	GNRMC	GNVTG

Note1: Before 3D fix RMC output is GPRMC, after 3D fix it changes to GNRMC.

## 11.2 NMEA command interface

GNS701 NMEA command interface allows to control settings and the extended functions. The command interface specification is available in an extra document:  
*GPS/GLONASS\_NMEAcommandInterface manual.*

Two groups of commands are available:

Setting commands do modify the behavior of the module.

**Note** : Modified settings will be valid as long as the module is powered through VCC or VBACKUP. (f.e. : setting of a new baud rate). After removing VCC and VBACKUP, all settings are reset to their default values.

Action commands will perform the specified action one time after the command has been received. (f.e. : request for cold start)

Commands are always started with \$PTMK, directly followed by the command number 000..999. Each command must be terminated by \*<chksum> and a <CR><LF>. The checksum calculation is simple, just XOR all the bytes between the \$ and the \* (not including the delimiters themselves). Then use the hexadecimal ASCII format.

## 12 MATERIAL INFORMATION

Complies to ROHS standard  
ROHS documentations are available on request  
Contact surface: gold over nickel

### 13 RECOMMENDED SOLDERING REFLOW PROFILE

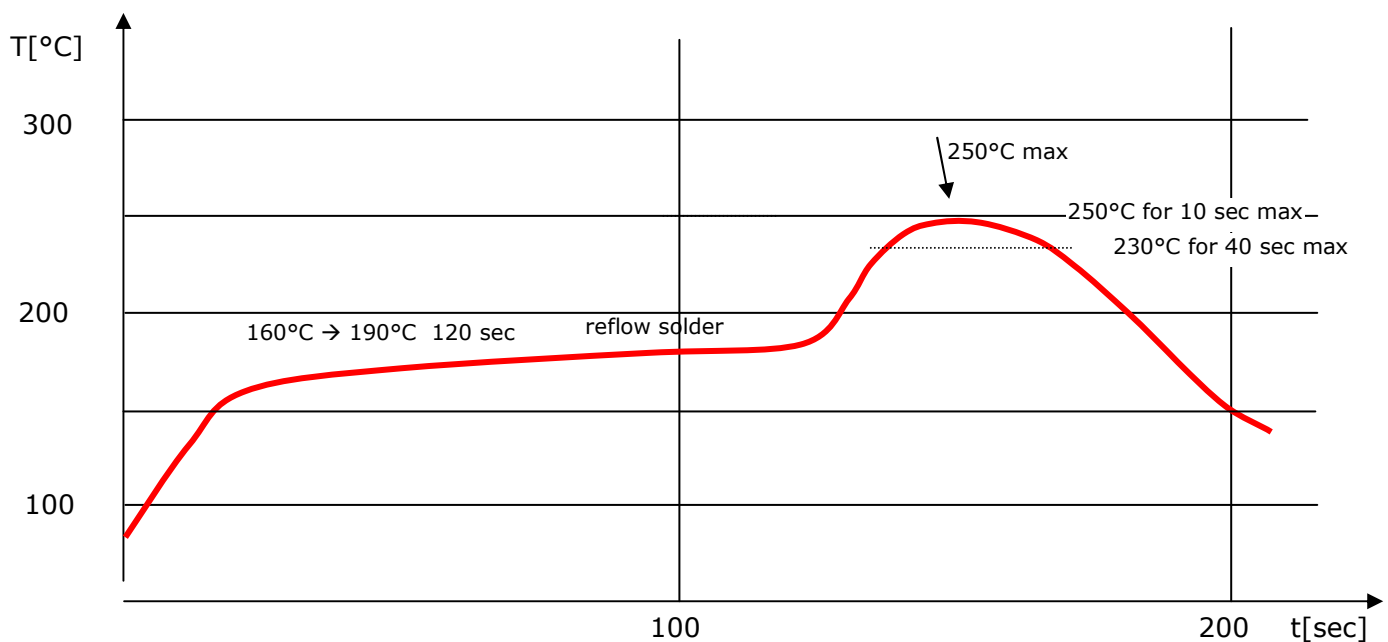

#### Notes:

1. GNS701 should be soldered in upright soldering position. In case of head-over soldering, please prevent shielding / GNS701 receiver from falling down.
2. Do never exceed maximum peak temperature
3. Reflow cycles allowed : 1 time
4. Do not solder with Pb-Sn or other solder containing lead (Pb)
5. This device is not applicable for flow solder processing
6. This device is not applicable for solder iron process

### 14 TRAY PACKAGE INFORMATION

The GPS receivers are placed on a tray for quantities below 100 pieces. The trays will be stacked and packed together. The trays are placed inside an antistatic bag.



### 15 TAPE&REEL INFORMATION

Tape information:

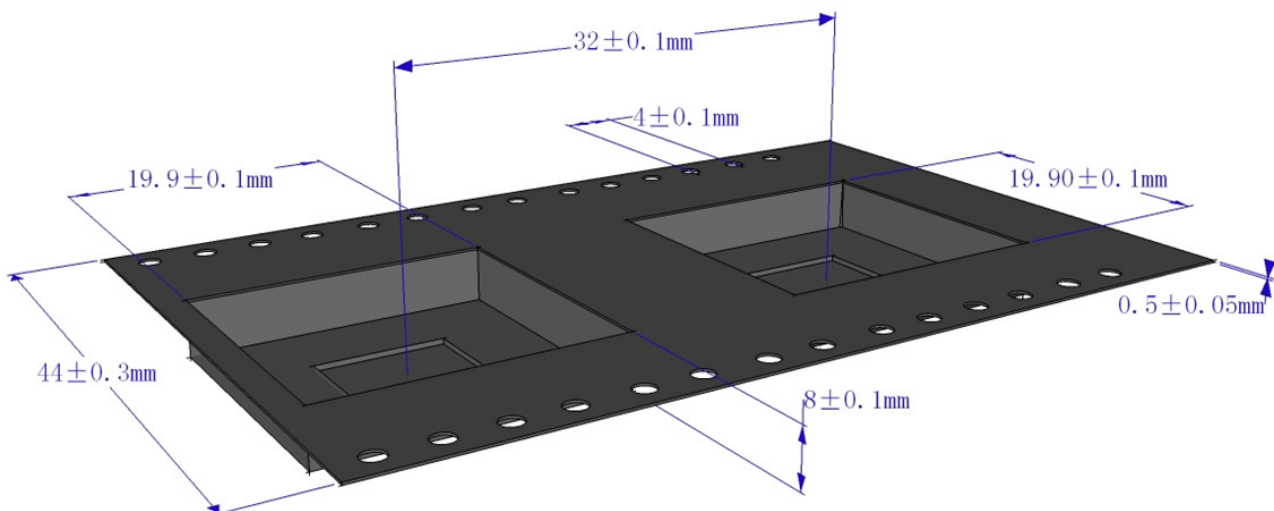

Reel information:

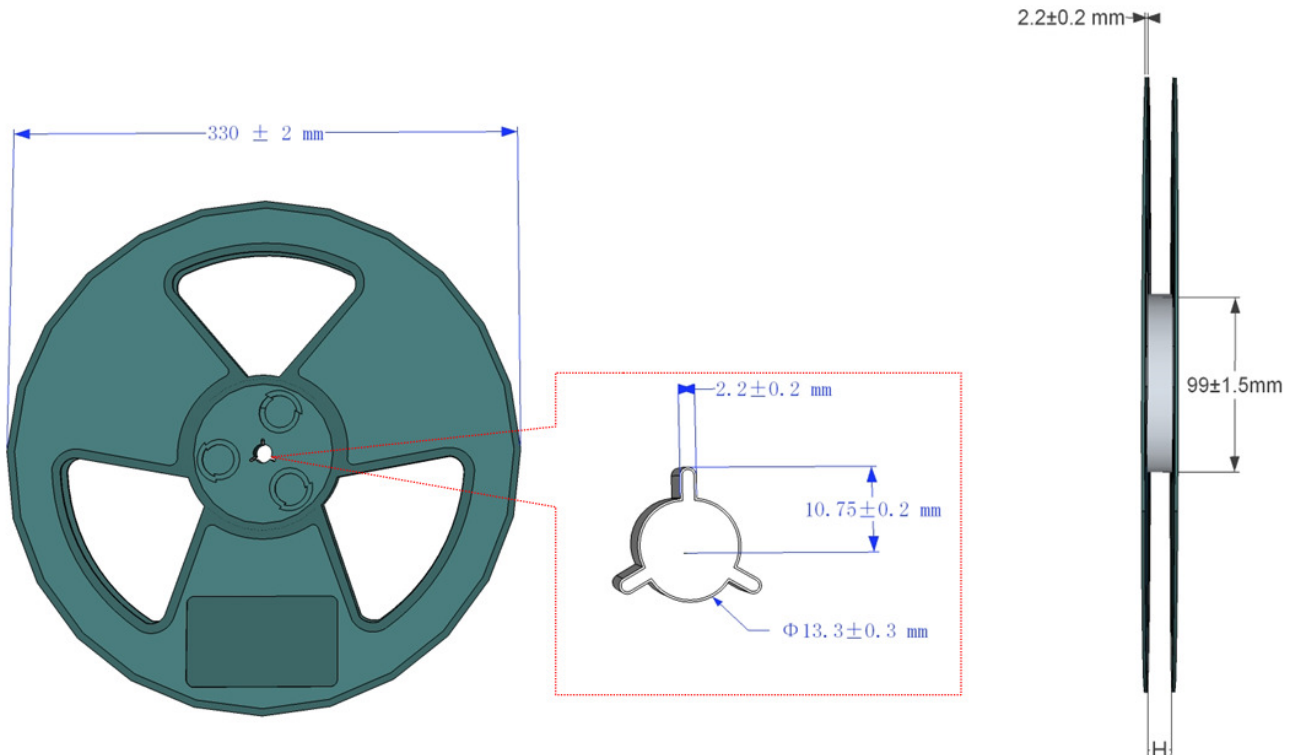

H= 44.5mm

Number of devices: 250pcs/reel

### 16 ORDERING INFORMATION

Ordering information			
Type	Part#	module marking	Description
GNS701	4037735104846	GNS701 SN18100630	1 <sup>st</sup> line : part name <b>GNS701</b> 2 <sup>nd</sup> line : <b>SNYYnnnnnn</b> YY : Year of production Nnnnnn : consecutive SN

### 17 FCC COMPLIANCE

This product has passed FCC 911 compliance successfully. The module emission and immunity has been proven to be compliant.

However, applications using this module as a component must pass CE and/or FCC again in whole.

### 18 Quality and Environmental Specifications

Test	Standard	Parameters
PCB Inspection	IPC-6012B, Class 2. Qualification and Performance Specification for Rigid Printed Boards - Jan 2007	
Assembly Inspection	IPC-A-610-D, Class 2 "Acceptability of electronic assemblies"	
Temperature Range	ETSI EN 300 019-2-7 specification T 7.3	-30 °C, +25 °C, +85 °C, operating
Damp Heat	ETSI EN 300 019-2-7 specification T 7.3	+70 °C, 80% RH, 96 hrs, non-operating
Thermal Shock	ETSI EN 300 019-2-7 specification T 7.3 E	-40 °C ... +85 °C, 200 cycles
Vibration	ISO16750-3	Random vibration, 10~1000Hz, 27.8m/s <sup>2</sup> , 8hrs/axis, X, Y, Z 8hrs for each 3 axis non-operating
Shock	ISO16750-3	Half-sinusoidal 50g, 6ms, 10time/face, ±X, ±Y and ±Z non-operating
ESD Sensitivity	JEDEC, JESD22-A114 ESD Sensitivity Testing Human Body Model (HBM), Class 2 JEDEC, JESD22-A115 ESD Sensitivity Testing Machine Model (MM), Class B	+2000V - Human hand assembly +200V - Machine automatic final assembly
Moisture/Reflow Sensitivity	IPC/JEDEC J-STD-020D.1	MSL3
Storage (Dry Pack)	IPC/JEDEC J-STD-033C	MSL3
Solderability	EN/IEC 60068-2-58 Test Td	More than 90% of the electrode should be covered by solder. Solder temperature 245 °C ± 5 °C

#### Moisture Sensitivity

GNS ships all devices dry packed in tape on reel with desiccant and moisture level indicator sealed in an airtight package. If on receiving the goods the moisture indicator is pink in color or a puncture of the airtight seal packaging is observed, then follow J-STD-033 "Handling and Use of Moisture/Reflow Sensitive Surface Mount Devices".

### Storage (Out of Bag)

The GNS 701 modules meet MSL Level 3 of the JEDEC specification J-STD-020D - 168 hours Floor Life (out of bag)  $\leq 30$  °C/60% RH. If the stated floor life expires prior to reflow process then follow J-STD-033 "Handling and Use of Moisture/Reflow Sensitive Surface Mount Devices".

## 19 DOCUMENT REVISION HISTORY

V1.0	Jan 29 2013	M.Reiff	initial document
V1.1	Apr 11 2013	M.Reiff	Tape&Reel information added; PPS direction at blockdiagram corrected; Related documents updated; Receiver default settings supplemented;
V1.2	Apr 25 2018	M.Heinzel	Quality and Environmental Specifications Updated label marking New author -> GNS Electronics GmbH
V1.3	Nov 27 2018	M.Heinzel	Elimination of the serial number sticker and direct printing of the serial number.
V1.4	Apr 1 2019	M.Heinzel	Extension to GALILEO



20 RELATED DOCUMENTS

Title	Description / file	Available from
<i>GPS/GLONASS NMEAcommandInterface manual</i>	Detailed description of NMEA commands	<a href="http://www.forum.gns-gmbh.com">www.forum.gns-gmbh.com</a>
<i>GNS701 StarterKit user manual</i>	User manual for the GNS701 receiver based evaluation kit	<a href="http://www.forum.gns-gmbh.com">www.forum.gns-gmbh.com</a>
<i>NMEA protocol</i>	Detailed description of NMEA protocol	<a href="http://www.forum.gns-gmbh.com">www.forum.gns-gmbh.com</a>

© GNS ELECTRONICS GMBH 2019

THE INFORMATION IN THIS DOCUMENTATION DOES NOT FORM ANY QUOTATION OR CONTRACT. TECHNICAL DATA ARE DUE TO BE CHANGED WITHOUT NOTICE.

NO LIABILITY WILL BE ACCEPTED BY THE PUBLISHER FOR ANY CONSEQUENCE OF THIS DOCUMENT'S USE.

REPRODUCTION IN WHOLE OR IN PART IS PROHIBITED WITHOUT THE PRIOR WRITTEN CONSENT OF THE COPYRIGHT OWNER