

PRELIMINARY SPECIFICATION

Part No.: **GNS1090EBDE1-T**

Date: **03.March.21**

Written by	Checked by	Approval
BB		

ELECTRICAL SPECIFICATIONS

Items	Content	UNIT
1	Center frequency (without tape on 70×70mm ground plane)	1090.0±3.0 MHz
2	-10dB Bandwidth MHz min	12
3	VSWR at CF max	2.0
4	Polarization Model	RHCP
5	Impedance	50 Ω
6	Frequency Temperature Coefficient	20ppm/deg.°C max

MECHANICAL SPECIFICATIONS

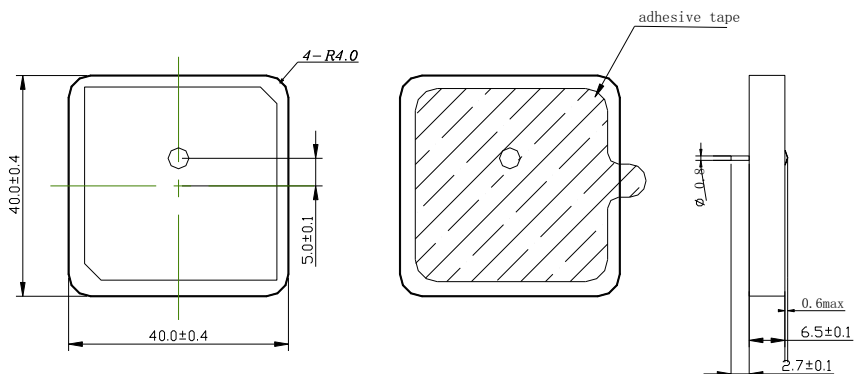

Impedance Characteristic

