

1 INTRODUCTION

GNS-Electronics, developer and manufacturer of module solutions for over 25 years, presents the new GNS5894T ADS-B module for 1090MHz "Virtual Radar" monitoring.

The high-dynamic signal processing circuit allows seamless ADS-B reception from near field to wide range. The module integrates a sensitive RF frontend, signal processing, a high speed data decoder and an output UART that can be easily connected to a host processor.

GNS5894T features a DSP-based hybrid reception algorithm that eliminates the so called "doughnut effect".

Features

- ADS-B all-in-one module
- Max. sensitivity -105dBm
- No "doughnut effect"
- Small outline 26x15x3.3mm
- Low power consumption : 73mA
- Frame decode indicator output
- Improved functionality by using a TCXO
- High Precision relative timestamp
- High Precision PPS synchronized absolute timestamp (with external GNSS receiver connected)
- Easy to mount stamp hole PCB design
- Evaluation Board with USB bridge available

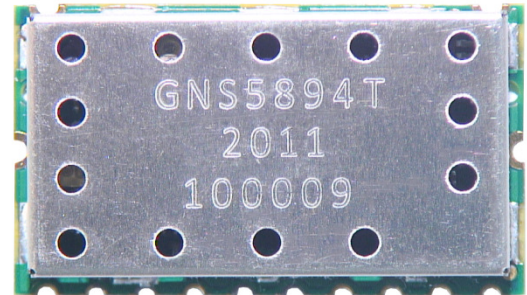

Applications

- Aviation safety
 - "Virtual Radar" for small aircrafts
 - Add-on data for flight navigation
- Ground equipment
 - Virtual Radar for ground based equipment
 - Hand held "plane spotting" devices
 - Data loggers for internet based online Virtual Radar systems
- Feeder for MLAT servers
 - Thanks to the high-precision time stamps that are added to each received Mode S / ADS-B frame, the GNS5894T can be used as feeder for a Multilateration (MLAT) server.

2 INDEX

1	INTRODUCTION	1
2	INDEX	2
3	BLOCK DIAGRAM	3
4	TYPICAL APPLICATION BLOCK DIAGRAM	3
5	DETAILED DESCRIPTION	4
5.1	UART Interface details	4
5.2	UART2 Interface details	6
5.3	Power supply	7
5.4	Reset input	7
5.5	Frame available output	7
5.6	RF input (RFin)	7
5.7	ADS-B antenna	7
6	ELECTRICAL SPECIFICATION	8
6.1	Absolute Maximum Ratings	8
6.2	Recommended Operating Conditions	8
6.3	Characteristics	8
6.4	RF input characteristics	8
7	DEVICE PINOUT DIAGRAM	9
8	ADS-B DATA	10
9	COMMAND INTERFACE	11
9.1	Command Message (Host → Device)	11
9.2	Text Protocol	11
9.2.1	Message Structure	11
9.2.2	Available Commands	12
9.2.3	ADS-B data frame reception	13
9.3	HULC Protocol	15
9.3.1	Packetizing & Line Encoding	15
9.3.2	Message Structure	15
9.4	Available Commands	18
10	PHYSICAL DIMENSIONS	19
11	RECOMMENDED PAD LAYOUT	20
12	MATERIAL INFORMATION	21
12.1	Shield Material Information	21
13	RECOMMENDED SOLDERING REFLOW PROFILE	21
14	TAPE INFORMATION	22
15	REEL INFORMATION	23
16	ORDERING INFORMATION	23
17	ENVIRONMENTAL INFORMATION	24
17.1	Quality and Environmental Specifications	24
18	DOCUMENT REVISION HISTORY	25
19	DISCLAIMER	25

3 BLOCK DIAGRAM

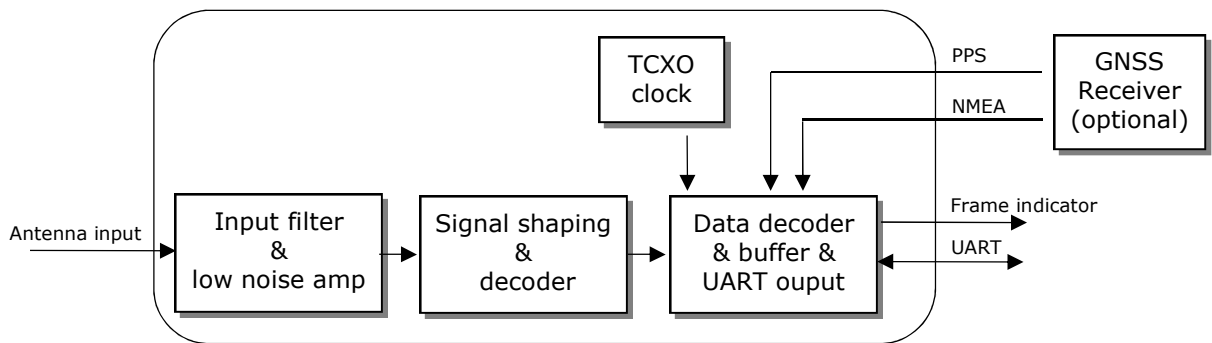

4 TYPICAL APPLICATION BLOCK DIAGRAM

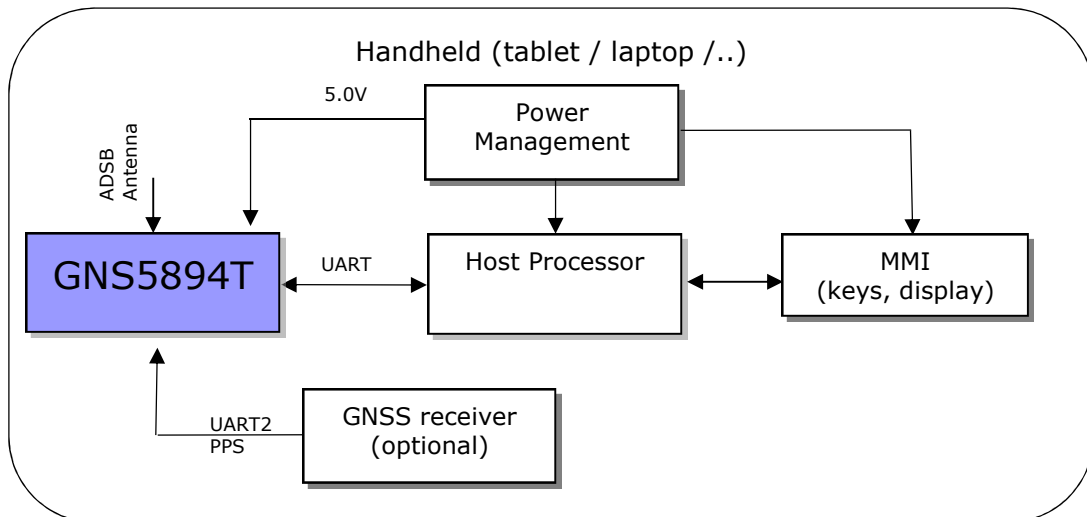

5 DETAILED DESCRIPTION

GNS5894T is a high performance receiver for ADS-B.

An appropriate power supply of 5.0V and a special antenna must be connected for operation.

Due to high input sensitivity it can work directly with a passive antenna.

By connecting an (optional) GNSS receiver, the GNS5894T is able to add high-precision absolute time stamps to each received data frame.

The improved RF architecture and outstanding decoder circuit together with the enhanced firmware provides maximum performance at minimum space and power requirements.

GNS5894T features a special ultra fast signal level adaption that overcomes the so called "doughnut effect". This input stage allows to receive very strong "near" and and very weak "far" signals at the same time without losses.

The signal picked from air is filtered and decoded without any host processing requirements.

ADS-B (mode-S) data as well as additional information required for MLAT triangulation (absolute or relative time stamps, RSSI) is provided at the serial UART port. An appropriate host system with application must read and interpret the data and present them through the UI.

No external clocks are required.

5.1 UART Interface details

GNS5894T must be connected to the host system by a UART Interface.

There are 2 different transmission protocols available:

- The Text protocol, known to many users as AVR protocol, an open format just like hexdumping of the frame contents.
- The new 'HULC' protocol, based on the well-known 'BEAST' protocol.

The selection of the used protocol is done by hardware via pin11 'UART PS'. For more details see Chapter 9 (Command Interface).

For safe communication, implementing hardware handshake via RTS and CTS is recommended. I/O levels are 3.3V (see electrical data).

ADS-B UART Default Settings			
Parameter	HULC protocol	Text protocol	Unit
Baud rate	921600	3000000	bit / sec
Data length	8	8	bit
Stop bit	1	1	
Parity	none	none	
Handshake	RTS/CTS	RTS/CTS	hardware

The idle state of the UART lines is positive voltage. To interface a standard RS232 UART (e.g. a PC serial interface), please add an inverting level shifter. To interface processors that have a different interfacing voltage level, level shifters are required.

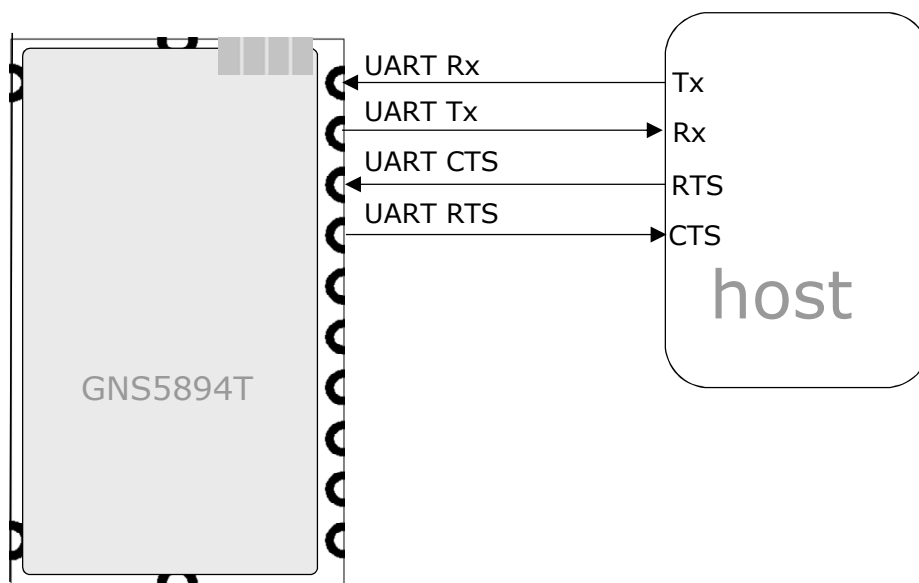

5.2 UART2 Interface details

The optional UART2 interface is used to connect an external GNSS (GPS) receiver. The NMEA data and the PPS signal of this receiver are used to generate an absolute time stamp information in each ADS-B frame in the HULC protocol.



The GNS5894T **only** processes **RMC** and **GGA** data sentences (1 sec update rate) for the time stamp calculation. Further data records as well as higher data rates may lead to faulty time stamps.

GPS UART2 Default Settings		
Parameter	Value	Unit
Baud rate	9600	bit / sec
Data length	8	bit
Stop bit	1	
Parity	none	
Handshake	none	

The GNSS data interface consists of a serial interface and a PPS input which can be connected to an external GNSS receiver. The GNS5894T receives the absolute time and the high precision GNSS based PPS pulse via this interface. The internal TCXO based timer is synchronized with this pulse.

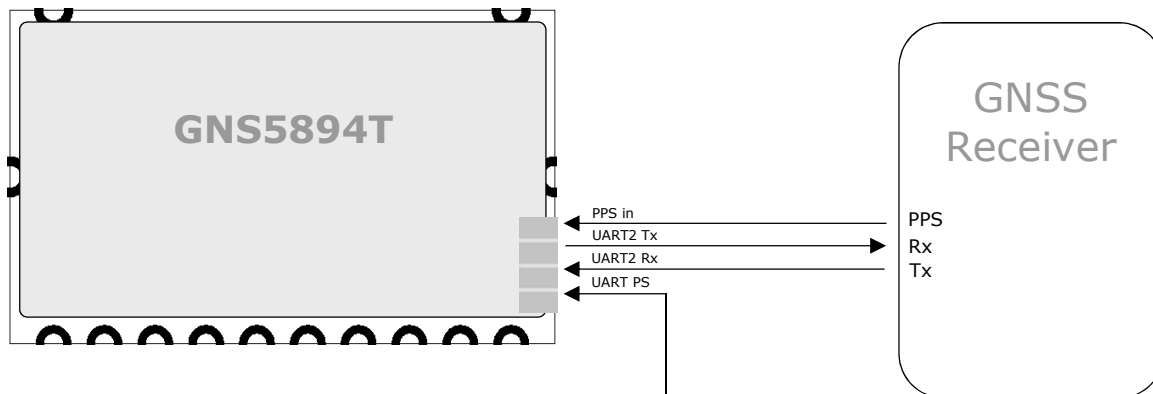

UART2 Interface description

UART PS Protocol Select	UART2 RX Serial Data from GNSS Receiver	UART2 TX Serial Commands & Data to Receiver	PPS in PPS Signal from GNSS Receiver
LOW HULC Protocol	NMEA GNSS Data	Reserved for Future Use (R.F.U.)	1 HIGH Pulse per Second
HIGH or OPEN Text protocol	Only RMC & GGA Sentences are processed		

5.3 Power supply

GNS5894T needs a single power supply of 4.3..5.5V. The current consumption is ~75mA at full operation.

5.4 Reset input

The reset input is optional. Drawing this pin to low will reset the internal microprocessor. Reset can be left open for the most applications.

5.5 Frame available output

The frame available signal is used to indicate frames being successfully decoded. The pin will be set to high whenever a frame or a block of frames come in. The signal can be used by a host processor or may drive a LED to provide a visual feedback of the incoming data frames.

5.6 RF input (RFin)

The RF input pin has a nominal impedance of 50 Ohms. Please keep tracks from module to antenna connector as short as possible. If more than a few millimetres track length is needed, the tracks must be impedance controlled (e.g. microstrip line). Please remember that the signal frequency is over 1 GHz. For connecting the antenna, a SMA or MCX connector should be used. On request, GNS can offer RF-support regarding PCB design.

5.7 ADS-B antenna

Depending on the application, a small rod antenna of just 20cm length can be used. This will provide a range of up to 350km around your location. However, using a high gain antenna will offer much more range and continuous tracking. Both types of antenna are available from GNS.

For antenna installation, it's important to know that ADS-B signals will spread linear only. Any obstacles like buildings, mountains or woods will mute or even totally block ADS-B-signals.

Antenna should be mounted to have an unobstructed "view" in all directions from a raised location.

ATTENTION: Risk of fire and injury ! For any raised mounted antenna constructions like roof antennas or aerial masts, it's mandatory to follow the rules for lightning protection. In case of doubt please consult a professional specialist

6 ELECTRICAL SPECIFICATION

6.1 Absolute Maximum Ratings

Parameter	Value	Unit
Supply voltage range: V_{dd}	0 to 5.5	V
DC Input voltage to antenna input ¹	-0.3 to V_{dd}	V
Input voltage to all other pins	-0.3 to 4	V
Operating ambient temperature range	-20 to +70	°C
Storage temperature range	-40 to +85	°C

6.2 Recommended Operating Conditions

Parameter	Min	Typ	Max	Unit	Note
V_{dd}	4.3	5.0	5.5	V	Power-supply voltage
High level output voltage V_{OH}	2.4		3.3	V	$I_{source} = 8 \text{ mA}$, pins 7,9,13
Low level output voltage V_{OL}	0		0.4	V	$I_{sink} = 8 \text{ mA}$, pins 7,9,13
High level output voltage V_{OH}	1.4		2.3	V	$I_{source} = 1 \text{ mA}$, pin 5
Low level output voltage V_{OL}	1.0		1.4	V	$I_{sink} = 1 \text{ mA}$, pin 5
High-level input voltage V_{IH}	1.8		4.0	V	pins 6,8,10,11,12,14
Low-level input voltage V_{IL}	0		1.2	V	pins 6,8,10,11,12,14
Operating temperature	-20		70	°C	Full specified performance

6.3 Characteristics

Parameter	Min	Typ	Max	Unit	Note
general					
Frequency		1090		MHz	ADS-B – mode S
Output data frequency		3		MBit/sec	Uart baudrate
UART baud deviation			0.1	%	
sensitivity	-105		+5	dBm	Frame detection level
Power consumption					
Current full operation		70	75	mA	
Supply voltage	4.3	5.0	5.5	V	

6.4 RF input characteristics

Parameter	Min	Typ	Max	Unit	Note
Input impedance		50		Ω	
Maximum input level			+5	dBm	before destruction
Input return loss		-11		dB	

7 DEVICE PINOUT DIAGRAM

TOP VIEW

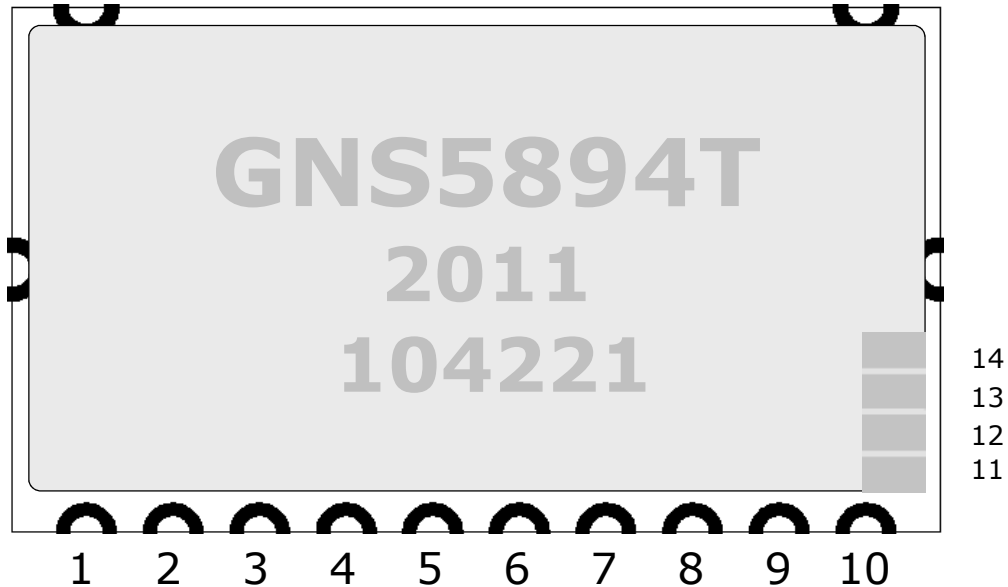

Pin	Name	I/O	Description & Note
1	RF Gnd	G	Antenna Ground
2	RF in	Ana	RF input ADS-B RF signal input pin.
3	Gnd	G	Supply Ground
4	Vdd	P	Main Supply voltage 5.0V
5	F_ind	O	Frame indicator Outputs positive pulses when receiving single ADS-B frames or groups of ADS-B frames. Internally driven by 3.3V / 1kOhm.
6	RESET	I	Reset input. Low active, causes the module to reset. Internally pulled up by 10kOhm, if not used keep floating.
7	UART RTS	O	Request To Send. Low active, UART H/W handshake output signal.
8	UART CTS	I	Clear To Send. Low active, UART H/W handshake input signal.
9	UART Tx	O	ADS-B data from GNS5894T GNS5894T supports 2 different protocols. See chapter 5.1 (UART interface details) for more information.
10	UART Rx	I	ser. commands from host MCU
11	UART PS	I	Protocol Select Internally weakly pulled up. LOW : HULC protocol HIGH or OPEN : Text protocol.
12	UART2 Rx	I	Serial NMEA Data from ext. GPS receiver (@3.3V), 9600bd The GPS data is used to process the absolute MLAT time stamp.
13	UART2 Tx	O	Serial commands & data (optional) to ext. GPS receiver Reserved for future use.
14	PPS in	I	Pulse Per Second signal from ext. GPS receiver (@3.3V) The PPS signal is used to process the absolute MLAT time stamp.

G=Ground; Ana = analogue; P=power supply; O= dig. Output(3.3V); I=digital Input(3.3V)

8 ADS-B DATA

There are 25 possible types that will be all available, but for Virtual Radar applications, type 11 and 17&18 (extended squitter) are most important.

The following table shows all types in a short form. For further information, please refer to ADS-B specifications, for example the publications from ICAO (International Civil Aviation Organization).

Mode-S reply available sentences								
DF	Type						content	
00000	VS:1	7	RI:4	2	AC:13	AP:24	Short air-air surveillance (ACAS)	
00001	27 or 83						P:24	Reserved
00010	27 or 83						P:24	Reserved
00011	27 or 83						P:24	Reserved
00100	FS:3	DR:5	UM:6	AC:13	AP:24		Surveillance, altitude reply	
00101	FS:3	DR:5	UM:6	ID:13	AP:24		Surveillance, identify reply	
00110	27 or 83						P:24	Reserved
00111	27 or 83						P:24	Reserved
01000	27 or 83						P:24	Reserved
01001	27 or 83						P:24	Reserved
01010	27 or 83						P:24	Reserved
01011	CA:3		AA:24		PI:24		All-call reply	
01100	27 or 83						P:24	Reserved
01101	27 or 83						P:24	Reserved
01110	27 or 83						P:24	Reserved
01111	27 or 83						P:24	Reserved
10000	VS:1	7	RI:4	2	AC:13	MV:56	AP:24	Long air-air surveillance (ACAS)
10001	CA:3	AA:24		ME:56		PI:24	Extended squitter	
10010	CF:3	AA:24		ME:56		PI:24	Extended squitter/non transponder	
10011	AF:3	104						Military extended squitter
10100	FS:3	DR:5	UM:6	AC:13	MB:56	AP:24	Comm-B, altitude reply	
10101	FS:3	DR:5	UM:6	ID:13	MB:56	AP:24	Comm-B, identify reply	
10110	27 or 83						P:24	Reserved for military use
10111	27 or 83						P:24	Reserved
11xxx	1	KE:1	ND:4	MD:80		AP:24	Comm-D (ELM)	

AA:Address announced ; AC:Altitude code ; AF:Application field ; AP:Address/parity ; AQ:Acquisition ; CA:Capability ; CC:Cross-link capability ; CF:Control field ; CL:Code label ; DF:Downlink format ; DI:Designator identification ; DR:Downlink request ; DS>Data selector ; ELM:Extended length message ; FS:Flight status ; IC:Interrogator code ; ID:Identità ; KE:Control, ELM ; MA:Message, Comm-A ; MB:Message, Comm-B ; MC:Message, Comm-C ; MD:Message, Comm-D ; ME:Message, extended squitter ; MU:Message, ACAS ; MV:Message, ACAS ; NC:Number of C-segment ; ND:Number of D-segment ; PC:Protocol ; PI:Parity/interrogator identifier ; PR:Probability of reply ; RC:Reply control ; RI:Reply information ; RL:Reply length ; RR:Reply request ; SD:Special designator ; UF:Uplink format ; UM:Utility message ; VS:Vertical status

9 COMMAND INTERFACE

Two different protocols may be selected for Device →Host communication: the simpler ASCII based Text Protocol or the full-featured binary HULC Protocol. Both protocols share a common ASCII based Host →Device command-message. Protocols are selected during power-on using the UART PS - Pin.

The Text Protocol is largely compatible with the so-called AVR Protocol, whereas the HULC Protocol's Mode-S messages are compatible to the so-called Beast Binary Protocol in order to facilitate interfacing the GNS5894T to existing software.

Please note that the two protocols use different serial baud rates as specified in their respective chapters below.

9.1 Command Message (Host →Device)

The command-message has a simple ASCII based structure. Each message starts with a '#' (0x23) and ends with '<CR><LF>' (0x0D, 0x0A). In-between are one to 16 bytes in 2-digit hexadecimal representation using upper-case letters, separated by '-' (0x2D).

For example:

'#00<CR><LF>' or hexadecimal 0x23 0x30 0x30 0x0D 0x0A

'#43-02<CR><LF>' or hexadecimal 0x23 0x34 0x33 0x2D 0x30 0x32 0x0D 0x0A

The first byte is mandatory and holds the command while the remaining bytes are parameters.

Available commands depend on the selected protocol and are discussed in the respective protocol section.

9.2 Text Protocol

Serial Port Parameters: 3 Mbps, 8N1, RTS/CTS-Handshake

Normal and MLAT Mode as well as commands 0x00 and 0x43 are compatible with AVR Protocol.

9.2.1 Message Structure

Depending on the selected mode, the following Mode-S data messages are emitted:

<Mode-S Data> is used as a placeholder for either 7 bytes (Short Squitter) or 14 bytes (Extended Squitter) of Mode-S data formatted as a row of 2-digit uppercase hexadecimal bytes without separation.

Normal Mode (default):

Format: '*' <7 or 14 byte of 2-digit hexadecimal data> ';' <CR><LF>

Example Short Squitter: *5D4951B4192B49; <CR><LF>

Example Ext. Squitter: *8D4951B49945B40CE8589F6181B6; <CR><LF>

MLAT Mode (option):

Format: '@' <6 byte Timestamp> <7 or 14 bytes of 2-digit hexadecimal data> ';' <CR><LF>

<6 byte Timestamp>: 6 byte MSB-first free running 12 MHz counter value as 12-digit hex

Example Short Squitter: @1122334455665D4951B4192B49; <CR><LF>

Example Ext. Squitter: @1122334455668D4951B49945B40CE8589F6181B6; <CR><LF>

RSSI Mode (option):

Format: '+' <1 byte RSSI> <7 or 14 bytes of 2-digit hexadecimal data> ';' <CR><LF>

<1 byte RSSI>: 1 byte uncalibrated logarithmic RSSI value as 2-digit hex

Example Short Squitter: +AB5D4951B4192B49; <CR><LF>

Example Ext. Squitter: +AB8D4951B49945B40CE8589F6181B6; <CR><LF>

<Mode-S Data> is used as a placeholder for either 7 bytes (Short Squitter) or 14 bytes (Extended Squitter) of Mode-S data formatted as a row of 2-digit uppercase hexadecimal bytes without separation.

Reply (to a command message):

Format: '#' <cmd> '-' <p00> '-' <p01> '-' <p02> '-' ... '-' <p13> '-' <p14> <CR><LF>

<cmd>: Original command for which this is a reply as 2-digit hex

<pXX>: Total of 15 parameter bytes (XX = 00..14) as 2-digit hex

9.2.2 Available Commands

Command 0x00 – Version Request

Message: #00<CR><LF>

Reply: #00-00-80-04-81-yy-ww-bb-xx-xx-xx-xx-xx-xx-xx-xx-xx-xx<CR><LF>

Parameter	Note
p00 .. p03	Fixed 00-80-04-81 for compatibility reasons
p04 .. p06	yy-ww-bb is Version year, week, build-number
p07 .. p14	Internal Use

Example

Cmd: #00<CR><LF>

Rpl: #00-00-80-04-81-14-05-03-01-02-03-01-00-00-00-00-00-00<CR><LF>

(14-05-03 -> v20.5.3)

Command 0x43 – Mode Command/Request:

Message: #43<CR><LF>

p00 (mm) is the optional Mode parameter. If omitted, the current mode is returned.

Reply: #43-mm-00-00-00-00-00-00-00-00-00-00-00-00-00-00-00<CR><LF>

p00 (mm) is the current mode.

The Mode byte is split into the 4 lower bits that form the output mode number and four upper bits used for option flags.

Output Mode	Note
0	Mode-S data OFF
1	Reserved, do not use
2	Output all Mode-S data, default
3	Output ADS-B data only (DF17-19)
4	Output ADS-B data with valid CRC only

Mode Flags	Note
0x10	MLAT Mode (do not combine with 0x80)
0x80	RSSI Mode (do not combine with 0x10)

Example – Set Output to MLAT with all Mode-S data (Mode 0x12):

Cmd: #43-12<CR><LF>

Rpl: #43-12-00-00-00-00-00-00-00-00-00-00-00-00-00-00<CR><LF>

Example – Read current Mode:

Cmd: #43<CR><LF>

Rpl: #43-02-00-00-00-00-00-00-00-00-00-00-00-00-00-00<CR><LF>

(p00 = 0x02 -> Flags = 0: Normal Mode; Output Mode = 2: All Mode-S)

9.2.3 ADS-B data frame reception

mode 2 (reception of all DF-Data)

In case of ADS-B mode 2 (reception of all DF-Data) the 56bit or 112bit raw data frames are output as 14 bytes ASCII frames , or 7 bytes ASCII frames, MSB first.

Every ASCII frame begins with an '*' and is finished by ';' + <CR><LF>.

Example:

```
....
*8D4B1621994420C18804887668F9;          *280008006C738F;
*02E1991058EF31;                        *5D3C5961BAAB6C;
*20000CB10D89FB;                         *8D4CA27A608145305B0B09EAD8B5;
*20001196553C25; *02E198BFAF8676;       *02E19838575F0A;
*02C18CB14E2D98;
*02E198BFAF8676;
*200015301CB296;
*20000F971E4582;
*200015B3EF4577;
*583E1BDABC2735;
```

Remark:

*8D.... is DF18 **Extended squitter**

*5D.... is DF11 **All-call reply**

mode 2+ (recept. of all DF-Data with add. Signal Strenght Indicator)

In case of ADS-B mode 2+ (reception of all DF-Data with additional Signal Strenght Indicator) the 56bit or 112bit raw data frames are output as 15 bytes ASCII frames , or 8 bytes ASCII frames, MSB first.

Every ASCII frame begins with an '+' and is finished by ';' + <CR><LF>.

The first byte following the '+' is the signal strength indicator of the current ADS-B frame.

The following bytes represent the received ADS-B data.

Example:

```
...
+218D406AE9990D3A19B004438721F4;
+2502E197187D90C5;
+21A00015B8C2680030A800004DFECE;
+2B8F471EE1EA13A864011C087DD2A6;
+275D40622B4E91A9;
+2702E197B07628F4;
+2128000C9453B470;
+23A8000821FFF9A134BFFCE51A6E88;
+21A8000821CF9A2131200C008672C4;
+27280000BA1A7AD8;
+215DAE027297612F;
+268D4CA97E58C386190B61D17C85EE;
+27A0281718D12A1131FFDC0185BBC5;
+225D40622B4E91A9;
+29A0281718C65000305400004835A6;
+27A000069D2010C23440D820B901DC;
+28200017B070F0BE;
+54A00017192015A676C50320F6CB14;
+83200005228A9442;
+268D3C49C9994169ACA00842E6CE77;
+28280000BA1A7AD8;
+34A0001838E159EF30FFFC0169CC03;
+3643B09E02A6481C;
+2002A18711E53A86;
+33A0001838CA380030A80000D50B50;
+285D40622B4E91D8;
+2102A18437F6ECC7;
+34200018385D2A25;
+23A0000437201571F6058820C1EA12;
...
```

Important note

The Signal Strength Indicator preceded by the data is only an indicator of the field strength of the received frame and not a measured value from which the distance to the transmitter can be bindingly derived. The range of the value is approximately between 0x20 (far distance signals) and 0xd5 (near distance signals).

9.3 HULC Protocol

Serial Port Parameters: 921.600 bps, 8N1, RTS/CTS-Handshake

Message structure, line encoding ('escaping') and Mode-S data messages are compatible with Beast Binary Protocol.

9.3.1 Packetizing & Line Encoding

HULC Protocol uses the byte 0x1A as start-of-packet (SOP) marker. In order to avoid misinterpretation of normal data bytes with value 0x1A as SOP, each occurrence of data byte 0x1A is doubled in the data stream during transmission ('escaping'). It is thus necessary during reception to detect every 0x1A not followed by another 0x1A as an SOP marker and to reduce every occurrence of a double 0x1A to a single 0x1A data byte ('un-escaping').

Example of a 4-byte long packet including SOP marker and 0x1A data bytes:

Before Escaping: **1A** 32 27 1A E8 57 F0 1A 6C
 During Transmission: **1A** 32 27 1A 1A E8 57 F0 1A 1A 6C
 After Un-Escaping: **1A** 32 27 1A E8 57 F0 1A 6C

9.3.2 Message Structure

All messages have the following basic structure (without escaping):

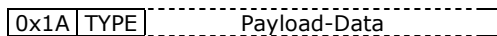

The following types are defined:

Type	Payload Size	Description
0x32	7 bytes	Mode-S Short Squitter raw data
0x33	14 bytes	Mode-S Extended Squitter raw data
0x48	variable	HULC Message, see below for details

Data Messages

All Data messages (Type 0x32 & 0x33) have the following structure:

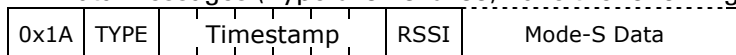

Fields:

TYPE 8-bit 0x32 or 0x33 for Mode-S short or extended squitter respectively
 Timestamp 48-bit¹⁾ Upper 18 bits are seconds since last midnight 00:00:00 UTC
 Lower 30 bits are nanoseconds of current second
 RSSI 8-bit Logarithmic field-strength indicator, uncalibrated
 Mode-S Data N * 8-bit Mode-S raw data, N = 7 for TYPE 0x32 and N = 14 for TYPE 0x33

¹⁾ MSB-first

Timestamps:

There are two distinct timestamp formats, absolute and relative timestamps depending on whether a GPS receiver is attached or not. To find out which format is used check bit 15 (*Gps Detected*) in the status flag field of the *HULC Status Message*. Both timestamp formats are compatible with the respective timestamp formats used in the *Beast Binary Protocol*.

Relative Timestamp (No GPS):

Without a GPS receiver attached the timestamp is a 48-bit unsigned number counting 12 MHz cycles. The timestamp will wrap approximately every 271 days.

Absolute Timestamp (With GPS):

If a suitable GPS receiver is attached the 48-bit timestamp field is divided into the upper 18 bits which count the seconds since last midnight 00:00:00 UTC and the lower 30 bits which carry the nanoseconds of the current second. Timestamp nanoseconds are guaranteed to be less than one complete second.

Example: $0x3746554be940 = (56601 \text{ sec} + 357296448 \text{ nsec}) = 15:43:21.357296448 \text{ UTC}$

HULC Messages

All HULC messages (Type 0x48) have the following structure:

0x1A	0x48	ID	LEN	LEN bytes of Data
------	------	----	-----	-------------------

Fields:

ID: HULC Message ID
 LEN: Number of bytes following

All multi-byte data within a HULC message is structured MSB-first!

The following IDs are defined:

ID	Description
0x01	Periodic HULC Status Message (~1/sec)
0x24	Reply to command

HULC Status Message (ID:1):

Periodic status message which is emitted every second

0x1A	0x48	0x01	0x18	SerNum	Flags	I.U.	xTime	Lat	Lon	Alt	Sat	HDOP
------	------	------	------	--------	-------	------	-------	-----	-----	-----	-----	------

Length of Data is currently 24 bytes but may be increased in the future by appending more fields. Thus any parser handling this message type should test for (LEN >= 0x18) and handle all fields known to them ignoring any additional data.

Fields:

SerNum	32-bit ¹	Device Serial Number
Flags	16-bit ¹	Status Flags*
I.U.	16-bit	Internal Use
xTime	32-bit ¹	Unix-Timestamp (Seconds since midnight 1970-01-01, UTC)
Lat	32-bit ¹	Latitude as 32-bit BAM 2, thus 232 ≡ 360°
Lon	32-bit ¹	Longitude as 32-bit BAM 2
Alt	16-bit ¹	Signed altitude meters
Sat	8-bit	Number of satellites used in fix
HDOP	8-bit	HDOP * 10, thus a value of 12 is HDOP 1.2

¹⁾ MSB-first

²⁾ https://en.wikipedia.org/wiki/Binary_scaling#Binary_angles

Status Flags:

- 1xxx xxxx xxxx xxxx - GPS device detected -> Using absolute timestamp
- x1xx xxxx xxxx xxxx - GPS valid (GGA, RMC present)
- xx1x xxxx xxxx xxxx - GPS currently has a valid fix
- xxx1 xxxx xxxx xxxx - High accuracy absolute time is available via PPS
- xxxx xxxx 1xxx xxxx - TX-Queue overflow since start-up (normal if HW-handshaking is used)
- xxxx xxxx x1xx xxxx - TX-Queue overflow during last second (probably due to HW-handshaking)
- xxxx xxxx xx1x xxxx - Excessive NMEA found (other than GGA/RMC)

Reply Message (ID:0x24) (to a command message):

0x1A	0x48	0x24	0x10	CMD	P00	P01	P14
------	------	------	------	-----	-----	-----	-------	-----

Length of Data is always 16 bytes.

Fields:

CMD	8-bit	The command for which this message is the reply
P00..14	8-bit each	Total of 15 parameter for the reply

9.4 Available Commands

Command 0x00 – Version Request:

Cmd: #00<CR><LF>

Reply: 1A 48 24 10 00 00 80 04 81 yy ww bb xx xx xx xx xx xx xx xx

Parameter	Note
p00 .. p03	Fixed 00-80-04-81 for compatibility reasons
p04 .. p06	yy-ww-bb is Version year, week, build-number
p07 .. p14	Internal Use

Example

Cmd: #00<CR><LF>

Rpl: 1A 48 24 10 00 00 80 04 81 14 05 03 01 02 03 01 00 00 00 00
(14-05-03 -> v20.5.3)

Command 0x43 – Mode Command/Request:

Cmd: #43 mm <CR><LF>

p00 (mm) is the optional Mode parameter. If omitted, the current mode is returned.

Reply: 1A 48 24 10 43 mm 00 00 00 00 00 00 00 00 00 00 00 00 00 00 00 00
p00 (mm) is the current mode.

The following modes (mm) are available in Hulc mode.

Output Mode	Note
0	Mode-S data OFF
1	Reserved, do not use
2	Output all Mode-S & Mode-A/C data, default
3	Output ADS-B data only (DF17-19)
4	Output ADS-B data with valid CRC only

10 PHYSICAL DIMENSIONS

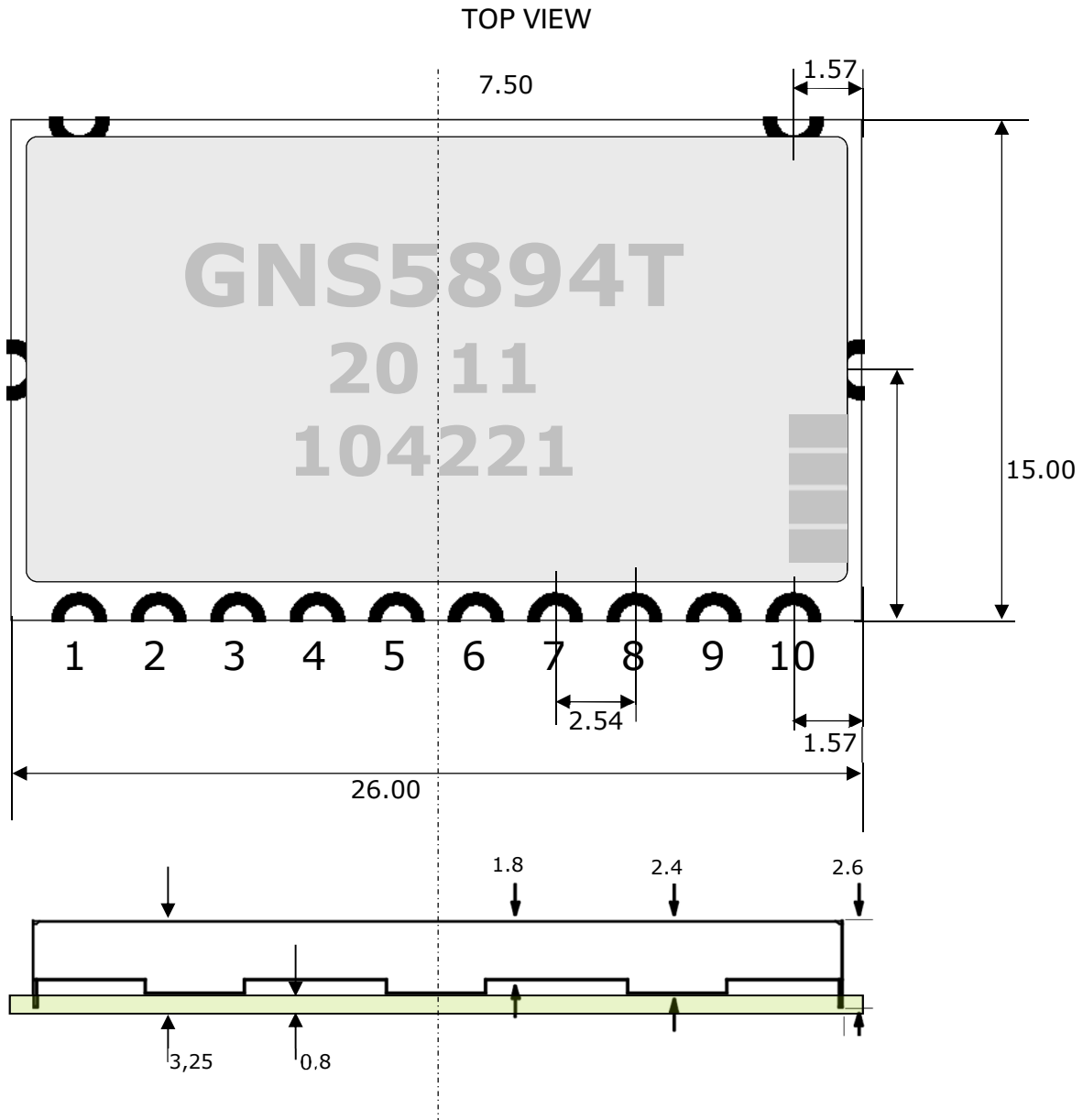

all units in mm

tolerance +/- 0.1 mm

11 RECOMMENDED PAD LAYOUT

TOP VIEW

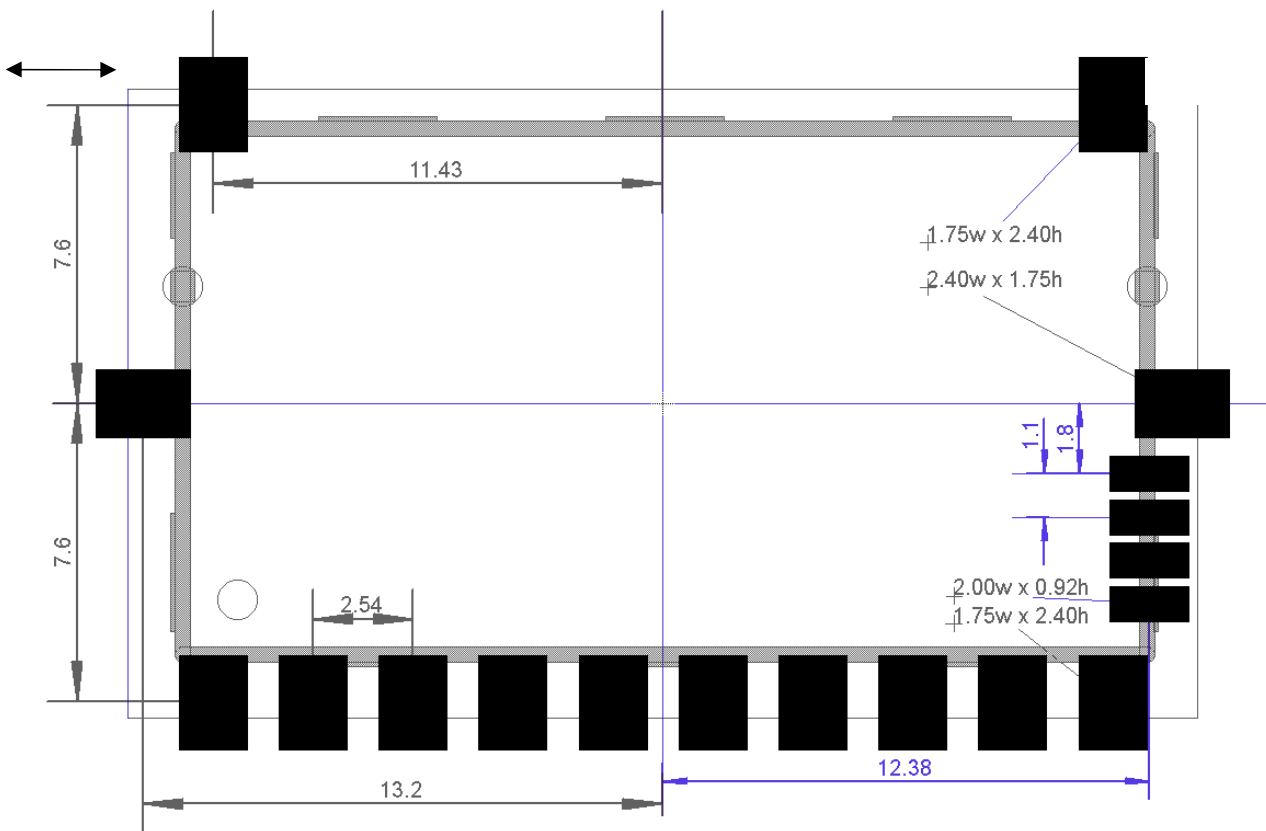

all units in mm

12 MATERIAL INFORMATION

12.1 Shield Material Information

"German Silver " , CuNi18Zn27
 Cu: 53.5..56.5%
 Ni : 16.5..19.5%
 Zn : 24..30%
 thickness :0.2mm

13 RECOMMENDED SOLDERING REFLOW PROFILE

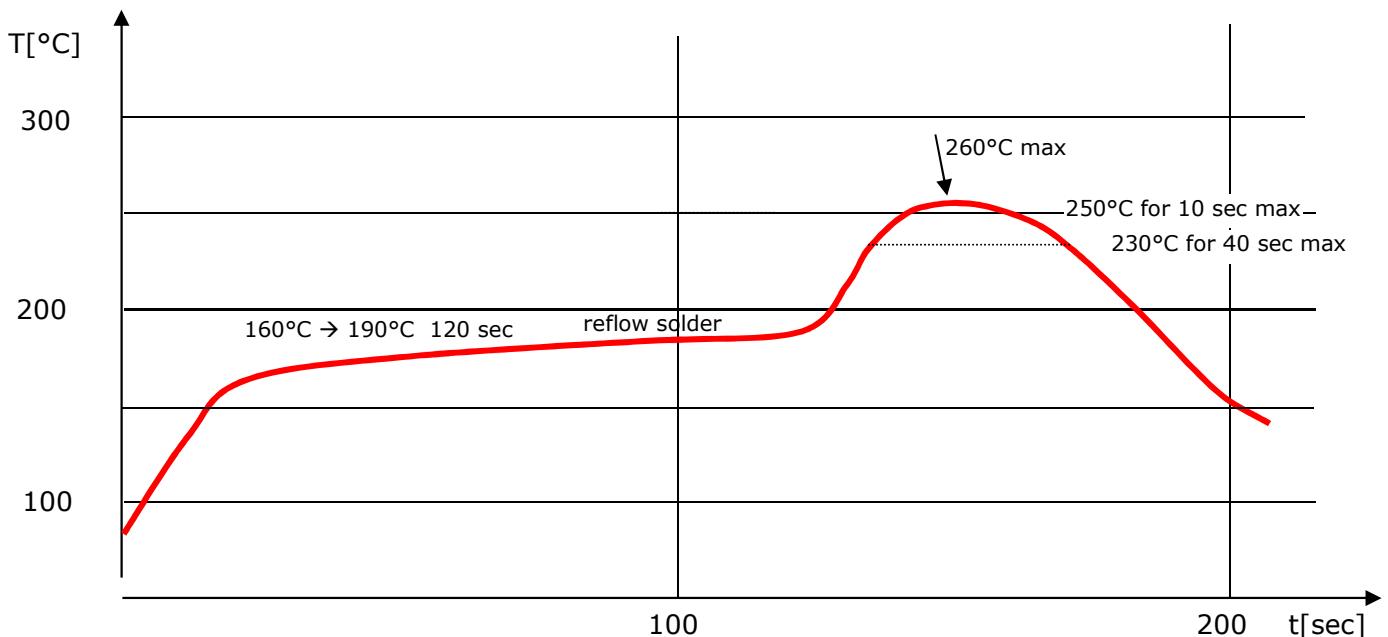

Notes:

1. GNS5894T should be soldered in upright soldering position. In case of head-over soldering, please prevent shielding / GNS5894T Module from falling down.
2. Do not exceed maximum peak temperature
3. Reflow cycles allowed : 1 time
4. Do not solder with Pb-Sn or other solder containing lead (Pb)
5. This device is not applicable for flow solder processing
6. This device is not applicable for solder iron process

14 TAPE INFORMATION

Component orientation:
arrow shows open-end
direction of tape

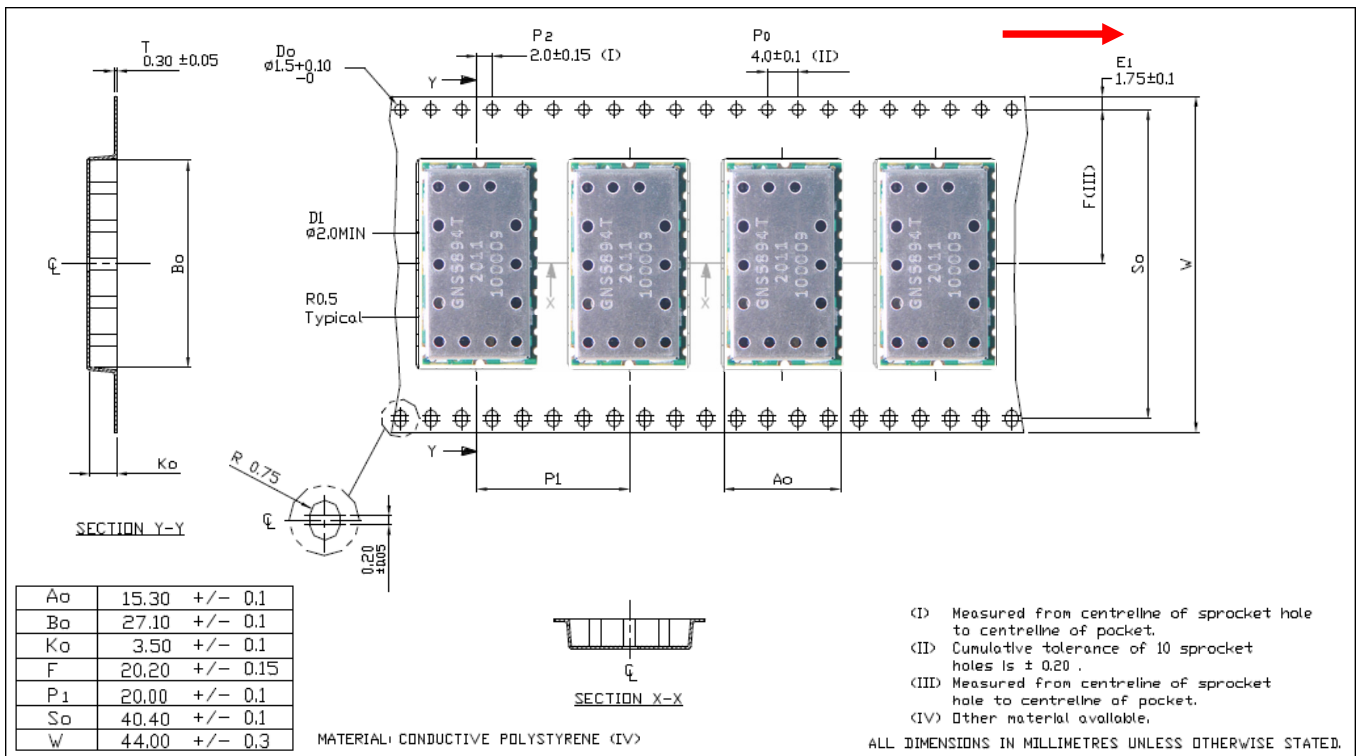

15 REEL INFORMATION

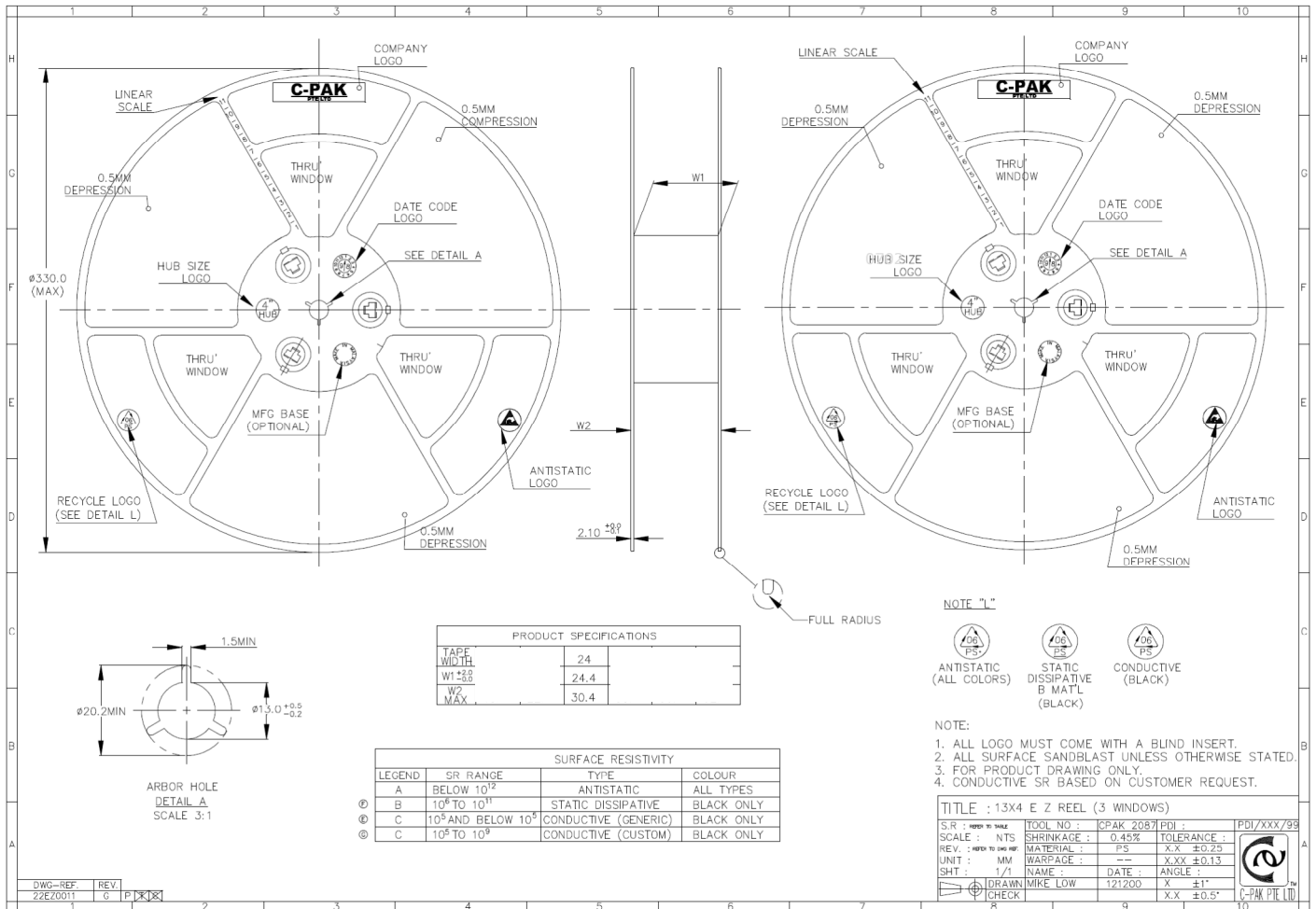

no. of devices : 500 pcs / reel

16 ORDERING INFORMATION

Ordering information			
Type	Part#	Laser marking	Description
GNS 5894T ADS-B module	4037735104793	GNS 5894T <yy cw> <serial#>	ADS-B serial module

17 ENVIRONMENTAL INFORMATION

This product is free of environmental hazardous substances and complies to 2015/863/EU. (RoHS 3 directive).

17.1 Quality and Environmental Specifications

Test	Standard	Parameters
PCB Inspection	IPC-6012B, Class 2. Qualification and Performance Specification for Rigid Printed Boards - Jan 2007	
Assembly Inspection	IPC-A-610-D, Class 2 "Acceptability of electronic assemblies"	
Temperature Range	ETSI EN 300 019-2-7 specification T 7.3	-30 °C, +25 °C, +85 °C, operating
Damp Heat	ETSI EN 300 019-2-7 specification T 7.3	+70 °C, 80% RH, 96 hrs, non-operating
Thermal Shock	ETSI EN 300 019-2-7 specification T 7.3 E	-40 °C ... +85 °C, 200 cycles
Vibration	ISO16750-3	Random vibration, 10~1000Hz, 27.8m/s ² , 8hrs/axis, X, Y, Z 8hrs for each 3 axis non-operating
Shock	ISO16750-3	Half-sinusoidal 50g, 6ms, 10time/face, ±X, ±Y and ±Z non-operating
ESD Sensitivity	JEDEC, JESD22-A114 ESD Sensitivity Testing Human Body Model (HBM), Class 2 JEDEC, JESD22-A115 ESD Sensitivity Testing Machine Model (MM), Class B	+2000V - Human hand assembly +250V - Machine automatic final assembly
Moisture/Reflow Sensitivity	IPC/JEDEC J-STD-020	MSL3
Storage (Dry Pack)	IPC/JEDEC J-STD-033C	MSL3
Solderability	EN/IEC 60068-2-58 Test Td	More than 90% of the electrode should be covered by solder. Solder temperature 245 °C ± 5 °C

Moisture Sensitivity

GNS ships all devices dry packed in tape on reel with desiccant and moisture level indicator sealed in an airtight package. If on receiving the goods the moisture indicator is pink in color or a puncture of the airtight seal packaging is observed, then follow J-STD-033 "Handling and Use of Moisture/Reflow Sensitive Surface Mount Devices".

Storage (Out of Bag)

The GNS5894T modules meet MSL Level 3 of the JEDEC specification J-STD-020D – 168 hours Floor Life (out of bag) ≤30 °C/60% RH. If the stated floor life expires prior to reflow process then follow J-STD-033 "Handling and Use of Moisture/Reflow Sensitive Surface Mount Devices".

18 <u>DOCUMENT REVISION HISTORY</u>				
Version	Revision	Date	Author	comment
V1.0	Primary	May 5 2020	M.Heinzel	Primary version
V1.1	Primary	May 25 2020	M.Heinzel	Minor changes in Huc protocol section
V1.2	Primary	Oct 29 2020	M.Heinzel	Chapter 9.4 Addition in the command interface

Document status

- Primary: Primary version, document content for design purpose, informal release
- Alpha release: Key customer preview version, document content has been preliminarily tested and verified, indicators may be fine-tuned later
- Beta release: Document content is verified by complete product testing and content indicators
- Production release: The document is complete and final

19 DISCLAIMER

THE USE OF THE DATA RECEIVED WITH GNS 5894T MODULE IS STRICTLY LIMITED TO PERSONAL ENTHUSIAST ACTIVITIES (I.E. FOR ENTERTAINMENT PURPOSES), WHICH SPECIFICALLY EXCLUDE ANY ACTIVITIES THAT MIGHT ENDANGER YOURSELF OR THE LIVES OF OTHERS. UNDER NO CIRCUMSTANCES, GNS WILL BE HELD RESPONSIBLE FOR INCIDENTS RESULTING FROM THE USE AND/OR INTERPRETATION OF THE DATA RECEIVED.

THE INFORMATION IN THIS DOCUMENTATION DOES NOT FORM ANY QUOTATION OR CONTRACT. TECHNICAL DATA ARE DUE TO BE CHANGED WITHOUT NOTICE.

NO LIABILITY WILL BE ACCEPTED BY THE PUBLISHER FOR ANY CONSEQUENCE OF THIS DOCUMENT'S USE.

REPRODUCTION IN WHOLE OR IN PART IS PROHIBITED WITHOUT THE PRIOR WRITTEN CONSENT OF THE COPYRIGHT OWNER

© GNS - ELECTRONICS GMBH 2020

THE INFORMATION IN THIS DOCUMENTATION DOES NOT FORM ANY QUOTATION OR CONTRACT. TECHNICAL DATA ARE DUE TO BE CHANGED WITHOUT NOTICE.

NO LIABILITY WILL BE ACCEPTED BY THE PUBLISHER FOR ANY CONSEQUENCE OF THIS DOCUMENT'S USE.

REPRODUCTION IN WHOLE OR IN PART IS PROHIBITED WITHOUT THE PRIOR WRITTEN CONSENT OF THE COPYRIGHT OWNER