

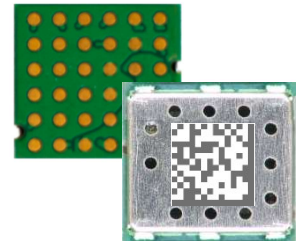

DATA SHEET

TC6000GN-D



V2.9 Dec 12, 2024

GNS Electronics GmbH
info@gns-electronics.com
Adenauerstr. 18
52146 Wuerselen
Germany

1 INTRODUCTION

TC6000GN-D is the new product designation of the previous **TC6000GN-P1**, where in the detail '-D' the used TCXO frequency is coded. More information about this can be found in chapter 6.3.

TC6000GN-D GPS module provides a high performance and low power GPS solution in a small form factor.

TC6000GN-D integrates a complete GPS receiver enabling RF to NMEA solutions that minimize the load on the host processor.

Features

- GPS all-in-one module
- GPS tracking & navigation sensitivity: -162dBm
- Dedicated GPS processing
- Low load on host CPU
- Standard NMEA 0183 interface
- Precision PPS Output
- Low power consumption (70mW at full operation)
- One single power supply (1.8V) needed
- Miniature 36 pin module (10x9.3x2.0) mm
- Evaluation Boards:
 - TC6000GN Starter Kit for testing on a PC

Applications

- Navigation
 - In-vehicle Navigation equipment
 - Dynamic Navigation
 - Portable ("nomadic") devices
 - Netbooks, tablet PCs and mobile phones
- Timing
 - Precision timing via GPS
- Location based applications
 - GPS Logger
 - GPS Tracker
 - Security devices
 - Camera equipment

2 INDEX

1 INTRODUCTION	1
2 INDEX	2
3 DETAILED FEATURES	3
3.1 Block diagram	3
3.2 GPS Features	3
4 TYPICAL APPLICATION BLOCK DIAGRAM	4
5 SYSTEM REQUIREMENTS	4
5.1 Real time clock (RTC)	4
5.2 I/O levels	4
6 GPS CORE	5
6.1 GPS core description	5
6.2 GPS characteristics	5
6.3 TCXO Frequency	7
6.4 GPS Power Management Features	7
6.5 GPS almanac and ephemeris data	7
6.6 Push to Fix	8
6.7 Pulse Per Second (PPS)	8
6.8 Fix Available	9
6.9 GPS Antenna	9
7 ELECTRICAL SPECIFICATION	10
7.1 Absolute Maximum Ratings	10
7.2 Recommended Operating Conditions	10
7.3 GPS input characteristics	10
8 DEVICE PINOUT DIAGRAM	11
9 RTC CONNECTION	14
10 HARDWARE HOST INTERFACE	15
10.1 GPS UART Interface details	15
11 NMEA DATA	15
12 PHYSICAL DIMENSIONS	16
13 RECOMMENDED PAD LAYOUT	17
14 MATERIAL INFORMATION	17
14.1 Shield Material Information	17
15 RECOMMENDED SOLDERING REFLOW PROFILE	18
16 TAPE INFORMATION	19
17 REEL INFORMATION	20
18 ORDERING INFORMATION	21
19 ENVIRONMENTAL INFORMATION	21
20 Quality and Environmental Specifications	22
21 DOCUMENT REVISION HISTORY	23
22 RELATED DOCUMENTS	25

3 DETAILED FEATURES

3.1 Block diagram

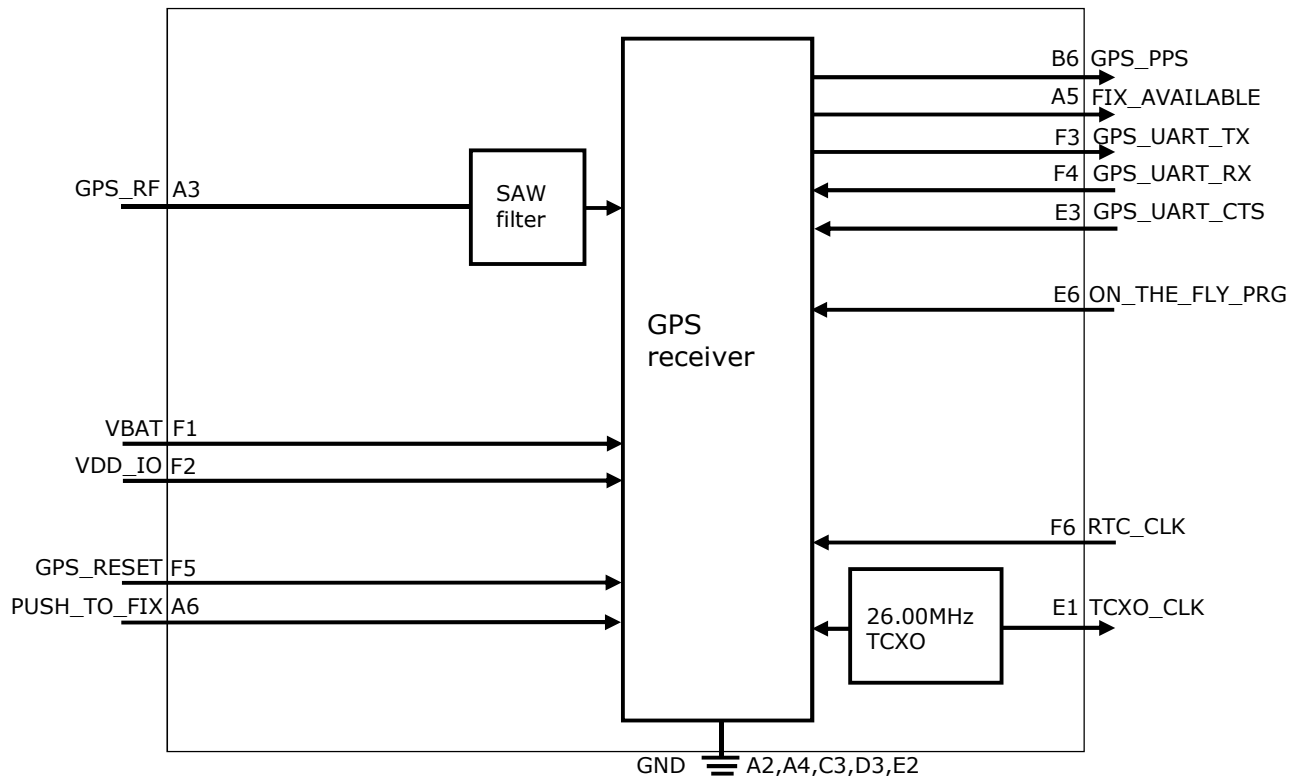

3.2 GPS Features

- Significantly improved TTFF at low signal power levels provides the consumer with a compelling GPS experience
- Improved acquisition performance to process position fixes in deep indoor conditions
- Reduced power consumption through improvements to RF architecture, software techniques, receiver core, and RF noise figure partitioning
- Improved tracking performance and minimized error in multi-path environments through increased IF bandwidth and higher sampling rates in tracking channels
- Standard NMEA output
- Precision 1PPS output
- GPS Fix indication output pin

4 TYPICAL APPLICATION BLOCK DIAGRAM

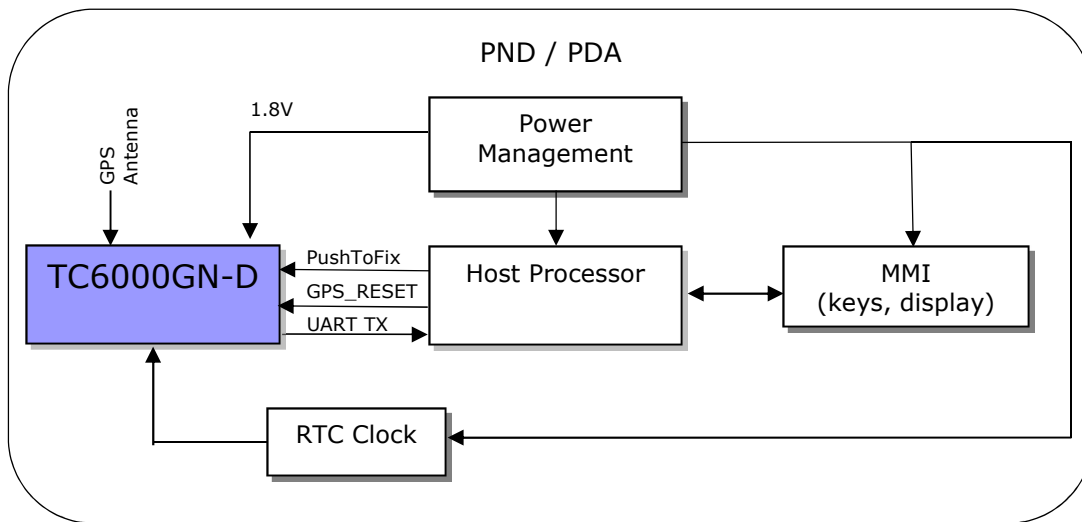

5 SYSTEM REQUIREMENTS

TC6000GN-D includes a complete GPS engine.

- GPS is fully processed without any host processing requirements
- Standard NMEA message output from the solution to the host
- RTC clock (32.768kHz) should be applied externally.

5.1 Real time clock (RTC)

TC6000GN-D requires a real time clock input that will provide time information for GPS after an off-time. The clock signal of 32.768kHz is not on-module and has to be fed at pin RTC_CLK . Additionally, the clock signal is needed for some other chip-internal purposes. See chapter *RTC Connection* for more details

5.2 I/O levels

TC6000GN-D core and I/O sections work at 1.8V nominal. Absolute Maximum Ratings should not be exceeded

Should the TC6000GN-D be interfaced to a host with I/O at higher levels, level shifters should be used.

No signals are allowed on the device I/Os in the absence of VDD_IO voltage because the most I/Os are **not** fail-safe. Not fail-safe means that the pins will draw undefined current from an external voltage applied to the pin, when no I/O power is supplied to the device. Only exception is RTC_CLK .

6 GPS CORE

6.1 GPS core description

The TC6000GN-D GPS core is a high performance, low power GPS receiver with integrated RF frontend.

Due to high input sensitivity it can work directly with a passive antenna.

The very short TTFF (Time To First Fix) and improved acquisition performance at low signal power levels is achieved through an enhanced receiver core architecture.

The improved RF architecture and software techniques reduce the average power consumption.

Minimized error in multi-path environments is achieved through increased IF bandwidth and higher sampling rates in tracking channels.

TC6000GN-D supports APM (adapted power management) schemes to lower the average power of the GPS core to below 27mW.

6.2 GPS characteristics

Parameter	Min	Typ	Max	Unit	Note
general					
Frequency		1575.42		MHz	GPS L1 C/A code
Output data frequency	1/60	1	1	1/sec	Configurable
Navigation&tracking sensitivity		-162	-163	dBm	
Acquisition sensitivity		-146	-147	dBm	autonomous
TTFF hotstart			1	sec	All SV's@-130dBm
TTFF hotstart			10	sec	All SV's @-155dBm
TTFF autonomous cold start		34		sec	All SV's @-130dBm
TTFF autonomous cold start		45		sec	All SV's @-142dBm
Number of channels tracking		16			
Number of acquisition channels		40			
Power consumption					
GPS ACTIVE (acquisition)		68	78.6	mA	NMEA frequency = 1/sec
GPS ACTIVE (tracking)		45	53.8	mA	NMEA frequency = 1/sec
GPS ACTIVE (tracking)	15			mA	NMEA frequency=1/sec, -130dBm, APM feature active
GPS shutdown		180		µA	GPS_RESET → GND
GPS deep sleep (RTC running)		80		µA	PUSH_TO_FIX → GND

Accuracy					
Static position error CEP68	-	2	-	m	Normal open sky in Field Horizontal position accuracy using open sky roof-top antenna
Static position error CEP95	-	3	-	m	Normal open sky in Field Horizontal position accuracy using open sky roof-top antenna
Static position error CEP68	-	-	2	m	Simulator feed , IONO and TROPO errors oN at -130 dBm power level
Static position error CEP95	-	-	3	m	Simulator feed , IONO and TROPO errors oN at -130 dBm power level
dynamic position error CEP68	-	-	3	m	Simulator feed , IONO and TROPO errors oN at -130 dBm power level
dynamic position error CEP95	-	-	4	m	Simulator feed , IONO and TROPO errors oN at -130 dBm power level
velocity error CEP68	-	-	0.1	m/s	Simulator feed , IONO and TROPO errors oN at -130 dBm power level
velocity error CEP95	-	-	0.7	m/s	Simulator feed , IONO and TROPO errors oN at -130 dBm power level
Accuracy for timepulse signal					
1PPS pulse duration	-	1	-	msec	
1PPS time jitter	-	-	100	nsec	Pulse rising edge deviation from expected pulse time, measured in a 300 seconds interval with full 3D fix.
1PPS rise and fall time			10	nsec	10%..90%
1PPS output impedance	-	10kΩ//20pF	-		
TCXO					
TCXO output frequency	-	26.000	-	MHz	±2.5 ppm
TCXO output impedance	-	1MΩ//5pF	-	-	
ITAR limits					
Operation altitude	-5,000	-	18,288	m	
Operation velocity	-	-	514	m/s	
Operation acceleration	-	-	-	m/s ²	No limit set

6.3 TCXO Frequency

The TI chipset used in the TC6000GN-D has been designed with technical foresight to operate at different TCXO frequencies. The TC6000GN-D is built with a 26,000MHz TCXO. Other TCXO frequencies are no longer available. (see *TC6000GN PCN 240726.pdf*)

Part Number	TCXO Frequency [MHz]	MPN	in preparation / available
TC6000GN-D	26.000	4037735106376	available since Jan 1 th 2021
TC6000GN-P1	26.000	4037735105249	no longer available
TC6000GN-P1	26.000	4037735104327	no longer available
TC6000GN-F	38.400	4037735106390	no longer available

6.4 GPS Power Management Features

Power management schemes implemented for any GPS system requires an optimally tuned performance for both accuracy of the position fixes and the average power consumed for best user experience. TC6000GN-D architecture achieves both these aspects by providing flexibility and design choices for the system integration based on wide range of use cases and by leveraging on the proven silicon methodologies. Also TC6000GN-D provides position, velocity and time (PVT) measurements without any host loading. This, coupled with the optional built-in power management option, reduces the overall system power budget.

Power management features

- APM feature provides overall GPS system power consumption of 27mW in tracking mode under open sky conditions.
However – same as for any GPS device - the accuracy and stability will be lowered due to reduced activity of the positioning algorithms. Since working parameters of APM are not adjustable, a field test is recommended to confirm usability of power saving algorithm.
- Can provide PVT solution without any load on the host, allowing a reduction in overall system power consumption.
- Position update rates selectable by order option. Max of 1 Hz update rate.

6.5 GPS almanac and ephemeris data

For quick re-acquisition of the GPS after off-times, the GPS engine should have access to almanac and ephemeris data. This data is permanently stored inside TC6000GN-D module. When the GPS is powered-up again, the data will be used to allow a quick re-acquisition, as soon as a coarse time information is available.

6.6 Push to Fix

The *Push to Fix* signal is used to initiate a GPS fix session. The signal is defined as active high when starting a GPS fix session. The session can be a cold, warm or host start fix, depending upon the availability and age of the assistance data.

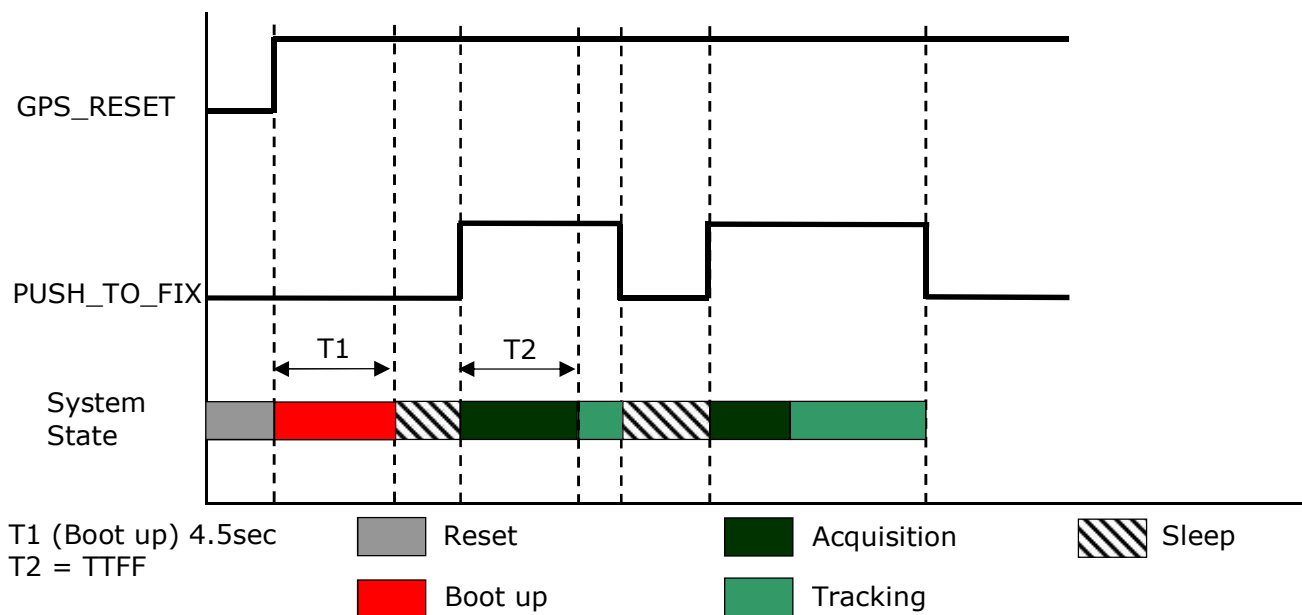

6.7 Pulse Per Second (PPS)

TC6000GN-D provides a so called Pulse Per Second (PPS) for timing purposes. After calculation of a 3D position fix, the PPS signal is accurately aligned to the GPS seconds boundaries. The pulse generated is approximately 1 millisecond in duration and the repetition rate is 1 second.

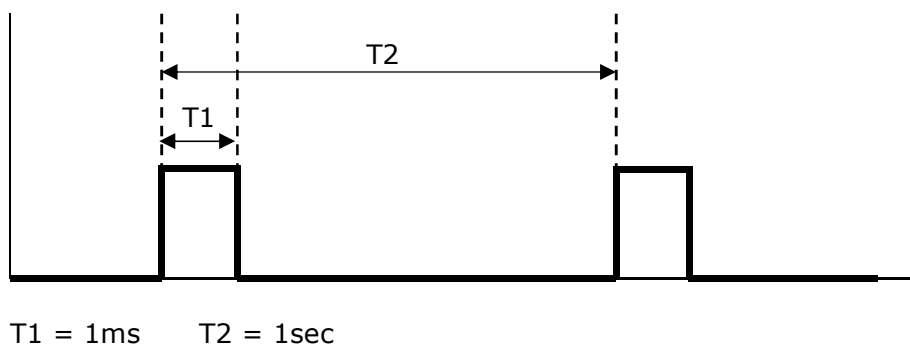

6.8 Fix Available

The *FIX AVAILABLE* signal is used to indicate the availability of GPS position information. This is typically used to drive an LED buffer so that the state of the device can be easily indicated. The table below lists the various states.

State	Indication
Initial boot up	low
PUSH_TO_FIX low	low
PUSH_TO_FIX on and acquisition	Toggling (900ms low and 100ms high)
PUSH_TO_FIX on and loss of fix	Toggling (900ms low and 100ms high)
PUSH_TO_FIX on and position fix	continuously high

6.9 GPS Antenna

TC6000GN contains all input circuitry needed to connect a passive GPS antenna directly. Depending on the application patch- or chip antennas or combo antennas (combination of GPS and Bluetooth) can be used. However, if there is a long wire between TC6000 GPS RF input and antenna, there should be an LNA (on the antenna side) to compensate for cable losses ("active" antenna). For active antenna configuration, the antenna supply DC must be blocked from the antenna signal line with a inductor **L** of 100nH and a 100pF capacitor **C** as shown in the diagram below.

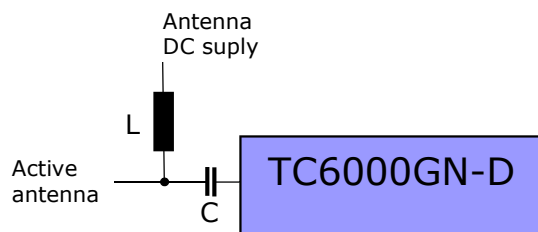

More information about connecting and implementing a GPS antenna to an application PCB, please refer to **GPS Antenna Connection Design Guide**.

7 ELECTRICAL SPECIFICATION

7.1 Absolute Maximum Ratings

Parameter	Value	Unit
Supply voltage range: VBAT	-0.5 to 2.1	V
Supply voltage range: VDD_IO	-0.5 to 2.1	V
Input voltage to analog pins ¹	-0.5 to 2.1	V
Input voltage to all other pins	-0.5 to (VDD_I/O + 0.5)	V

7.2 Recommended Operating Conditions

Parameter	Min	Typ	Max	Unit	Note
VDD	1.7		1.95	V	Power-supply voltage
VDD_IO	1.65		1.92	V	I/O power-supply voltage
High level output voltage V _{OH}	0.8 * V _{DD}		V _{DD}	V	IOUT = 4 mA
Low level output voltage V _{OL}	0		0.2*V _{DD}	V	IOUT = 0.4 mA
High-level input voltage V _{IH}	0.65x VDD_IO		VDD_IO	V	
Low-level input voltage V _{IL}	0		0.35x VDD_IO	V	
Operating temperature	-40		85	°C	Full specified performance
Storage temperature range	-40		85	°C	
Maximum ripple on VDD			60	mVpp	0 MHz to 0.1 MHz
			50	mVpp	0.1 MHz to 0.5 MHz
			30	mVpp	0.5 MHz to 1.7 MHz
			25	mVpp	1.7 MHz to 2.5 MHz
			15	mVpp	2.5 MHz to 3.3 MHz
		5	mVpp	Greater than 3.3 MHz	

7.3 GPS input characteristics

Parameter	Min	Typ	Max	Unit	Note
Input impedance		62.7-j3.2		Ω	
Maximum input level	0			dBm	before destruction
Input return loss	-10			dB	

8 DEVICE PINOUT DIAGRAM

TOP VIEW

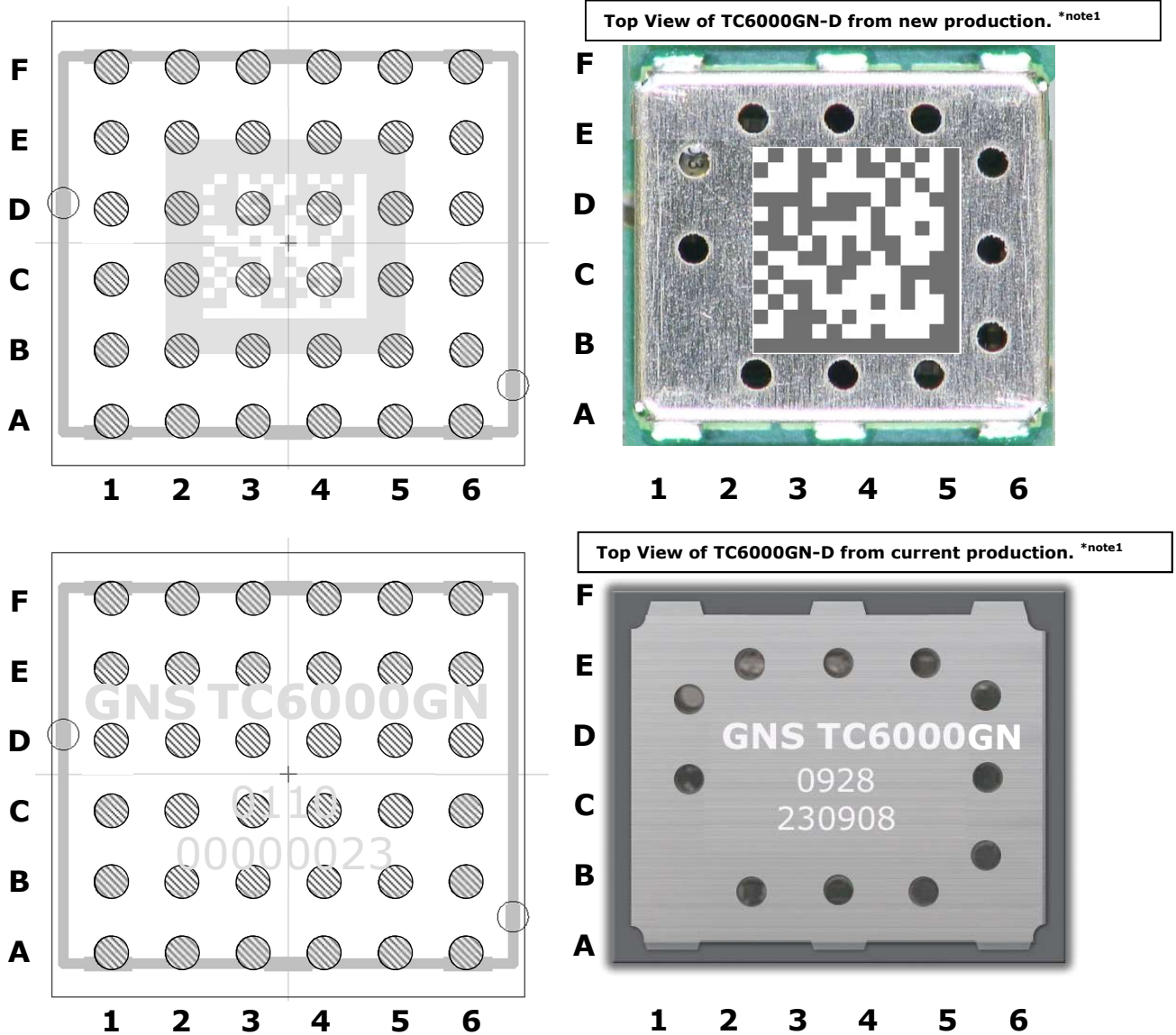

*note1: see more details in chapter 18 (Ordering Information).

F	VBAT	VDD_IO	GPS_UART_TX	GPS_UART_RX	GPS_RESET	RTC_CLK
E	TCXO_CLK	GND	GPS_UART_CTS	NU12	NU10	ON_THE_FLY_PRG
D	DB_1	DB_2	GND1	NU7	NU8	NU9
C	DB_3	DB_4	GND3	NU13	NU11	NU6
B	NU1	NU2	NU3	NU4	NU5	GPS_PPS
A	NU12	GPS_GND1	GPS_RF	GPS_GND2	FIX_AVAILABLE	PUSH_TO_FIX
	1	2	3	4	5	6

NO	NAME	TYPE ¹	DESCRIPTION
Power-Management Signals			
2F	VDD_IO	P	1.8V I/O power supply voltage
1F	VBAT	P	1.8V main power supply voltage
3D	GND1	P	Common Ground
2E	GND2	P	Common Ground
3C	GND3	P	Common Ground
Clock Signals			
1E	TCXO_CLK	O	TCXO_CLK signal output. This Pin delivers the high stable TCXO frequency for external components. Although the output is buffered, do not load this pin below 1MOhms // 5pF. Leave open if not used.
6F	RTC_CLK	I	Clock input: 32.768 kHz. Input for an external low frequency clock signal. A clock must be provided at this pin to operate the module. See chapter "RTC CONNECTION"
GPS Signals			
3A	GPS_RF	Ana	GPS RF Input, direct connection of passive or active GPS antenna
2A	GPS_GND1	P	GPS RF Ground
4A	GPS_GND2	P	GPS RF Ground
6B	GPS_PPS	O	This output delivers a high-precision pulse-per-second signal that is synchronized to the GPS time reference. The pulse precision is better than $1 \cdot 10^{-7}$ seconds. Although the output is buffered, do not load this pin below 10kOhms // 47pF (TBD). Leave open if not used.
6E	ON_THE_FLY_PRG	I	This input determines operation after reset. Internally pulled up for normal operation. pull low for re- programming firmware or reconfiguring the module. Leave open in normal operation.
6A	PUSH_TO_FIX	I	Input signal to switch between operation and deep sleep mode. internally pulled down. pull high (with less than 4.7kOhm) during operation. pull low (or leave open) to set the module to deep sleep. Internal RTC continues to work in deep sleep.
5A	FIX_AVAILABLE	O	This pin indicates a fix position. HIGH : 3D-fix available, BLINKING : no fix. Leave open if not used.
5F	GPS_RESET	I	Main Reset for the receiver. Internally weak pulled down. Pull high with less than 100kOhm for operation. pull to GND (or leave open) during power – up.
NOT USED PINS DO NOT CONNECT			
1A	NU12		do not connect or connect to GND
1B	NU1		do not connect or connect to GND
2B	NU2		do not connect or connect to GND
3B	NU3		do not connect or connect to GND
4B	NU4		do not connect or connect to GND
5B	NU5		do not connect or connect to GND
5E	NU10		do not connect or connect to GND
4D	NU7		do not connect or connect to GND
5D	NU8		do not connect or connect to GND
6D	NU9		do not connect or connect to GND
5C	NU11		do not connect or connect to GND
6C	NU6		do not connect or connect to GND
4E	NU12		do not connect or connect to GND
4C	NU13		do not connect or connect to GND
UART			
3F	GPS_UART_TX	O	Main UART TX.
4F	GPS_UART_RX	I	Main UART RX.
3E	GPS_UART_CTS	I	Main UART CTS. CTS not used. Leave open
I2C			
1D	DB_1		must be connected to DB_2
2D	DB_2		must be connected to DB_1
1C	DB_3		must be connected to DB_4
2C	DB_4		must be connected to DB_3

(1) I = INPUT; O = OUTPUT; I/O = BIDIRECTIONAL; P = POWER PIN; ANA = ANALOG PIN.

NOTE: SOME PINS HAVE BEEN REDEFINED FROM STATIC CONNECTION TO NOT USED (NU) IN THIS V0.26 DATASHEET. THE CONNECTIONS ARE NOW MADE INTERNALLY.

POWER MANAGEMENT

For quick re-acquisition after power-on, the TC6000GN should stay tied to Vcc during off-times to keep it's RTC clock running. The module is put in sleep mode, by holding the PUSH_TO_FIX pin low. The pin may be controlled by the host controller or by another power management circuitry, which might be also a simple electromechanical switch.

A static low level on PUSH_TO_FIX will keep the TC6000GN-D in a deep sleep with power consumption below 100µA.

9 RTC CONNECTION

The RTC_CLK is a free-running clock that needs to be supplied from an external clock source. It is connected to the RTC_CLK pin on the TC6000GN-D, and is a digital square wave signal in the range of 0 V to 1.8 V (nominal). The slow clock frequency is 32.768 kHz. RTC_CLK has multiple functionalities:

- Used to maintain GPS time between sleep intervals
- For clock frequency detection at power-on reset, before TCXO_CLK is available
- For power up sequencing.

Digital RTC Requirements					
Parameter	Min	Typ	Max	Unit	Note
Input slow clock frequency		32,768		Hz	
Input slow clock accuracy			±200	ppm	Initial temperature + aging
Input transition time			100	ns	t _R /t _F : 10% to 90%
Frequency input duty cycle	20%	50%	80%		
V _{IH}	0.65x VDD_IO		VDD_IO	V	Slow clock input voltage limits
V _{IL}	0		0.35xVDD_IO	V	Slow clock input voltage limits
Load capacitance			10	pF	Capacitance on RTC_CLK pin
Load resistance	1			MΩ	Resistance on RTC_CLK pin

10 HARDWARE HOST INTERFACE

TC6000GN-D is connected to host system by a UART Interface. Since TC6000GN-D is used only to deliver NMEA to the host only a single data line from the module to the host is necessary. The interface requires 1.8V I/O.

The idle state of the lines is positive voltage. To interface a standard RS232 UART (e.g. a PC serial interface), please add an inverting level shifter. To interface processors that have a different interfacing voltage level, level shifters are required.

10.1 GPS UART Interface details

- The UART interface is used to send NMEA messages and control data.
- The default baud rate is 9600, other baud rates can be selected by ordering option.
- The maximum baud rate deviation supported is $\pm 2\%$.

GPS UART Default Settings	
Parameter	Value
Baud rate	9600
Data length	8 bits
Stop bit	1
Parity	None

11 NMEA DATA

The TC6000GN-D provides NMEA 0183 (National Marine Electronics Association) compatible data. The following table shows the available NMEA sentences. All active NMEA sentences are sent at the selected rate.

NMEA available sentences	
Type	content
\$GPRMC	Recommended Minimum Navigation Information
\$GPGGA	Global Positioning System Fix Data, Time, Position and fix related data for a GPS receiver
\$GPGSV	Satellites in view
\$GPGLL	Geographic Position - Latitude/Longitude
\$GPGSA	GPS DOP and active satellites
\$GPVTG	Track made good and Ground speed

12 PHYSICAL DIMENSIONS

TOP VIEW

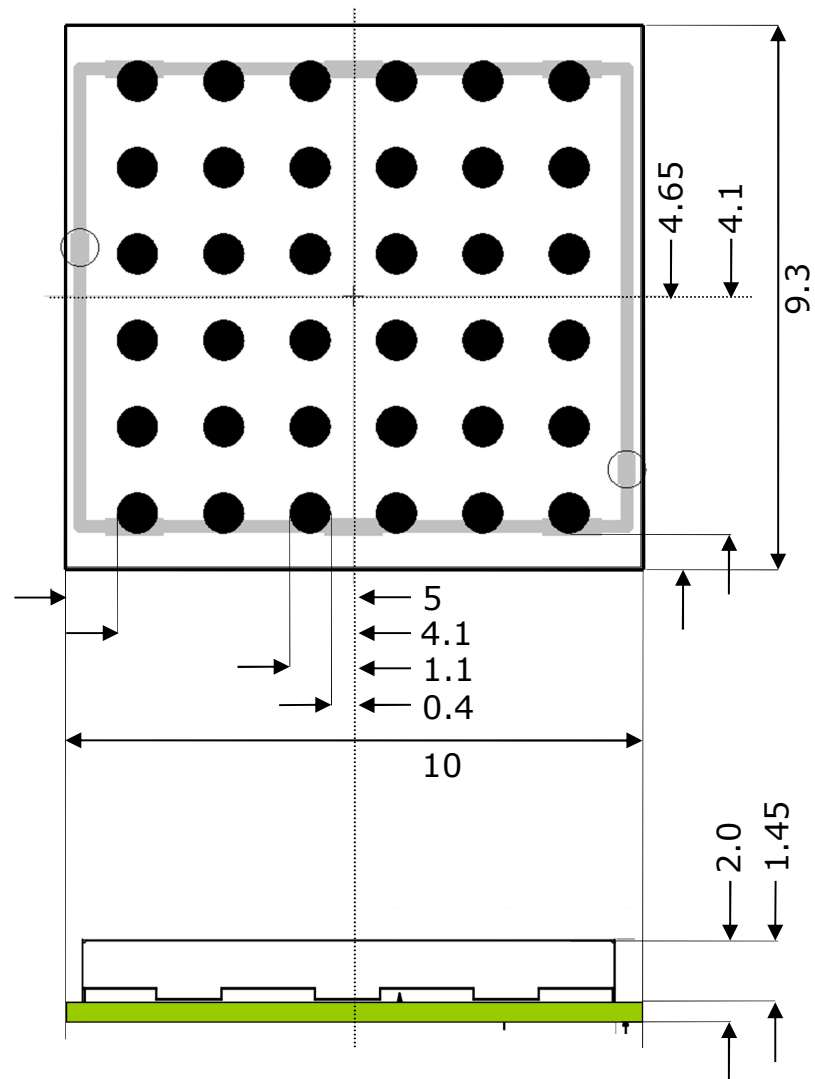

all units in mm

tolerance : $\pm 0.1\text{mm}$ for $< 5\text{mm}$, $\pm 0.2\text{mm}$ for $\geq 5\text{mm}$

13 RECOMMENDED PAD LAYOUT

TOP VIEW

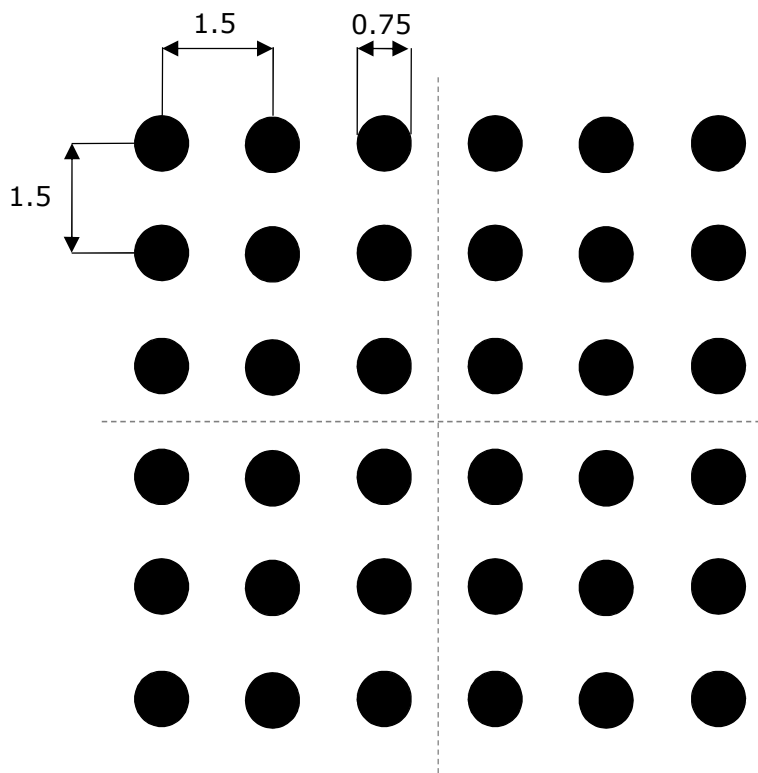

all units in mm

14 MATERIAL INFORMATION

Complies to ROHS standard
ROHS documentations are available on request
Contact surface : gold over nickel

14.1 Shield Material Information

"German Silver " , CuNi18Zn27
Cu: 53.5..56.5%
Ni : 16.5..19.5%
Zn : 24..30%
thickness :0.2mm

15 RECOMMENDED SOLDERING REFLOW PROFILE

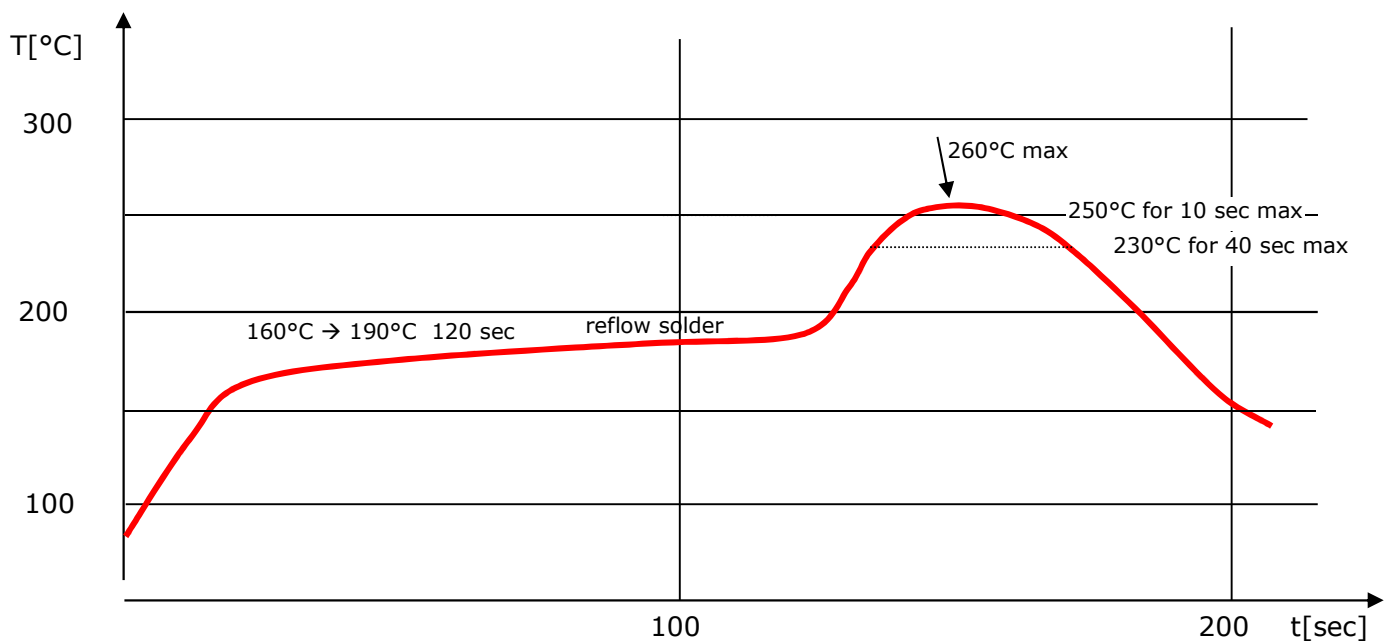

Notes:

1. TC6000GN-D should be soldered in upright soldering position. In case of head-over soldering, please prevent shielding / TC6000GN-D Module from falling down.
2. Do never exceed maximum peak temperature
3. Reflow cycles allowed : 1 time
4. Do not solder with Pb-Sn or other solder containing lead (Pb)
5. This device is not applicable for flow solder processing
6. This device is not applicable for solder iron process

16 TAPE INFORMATION

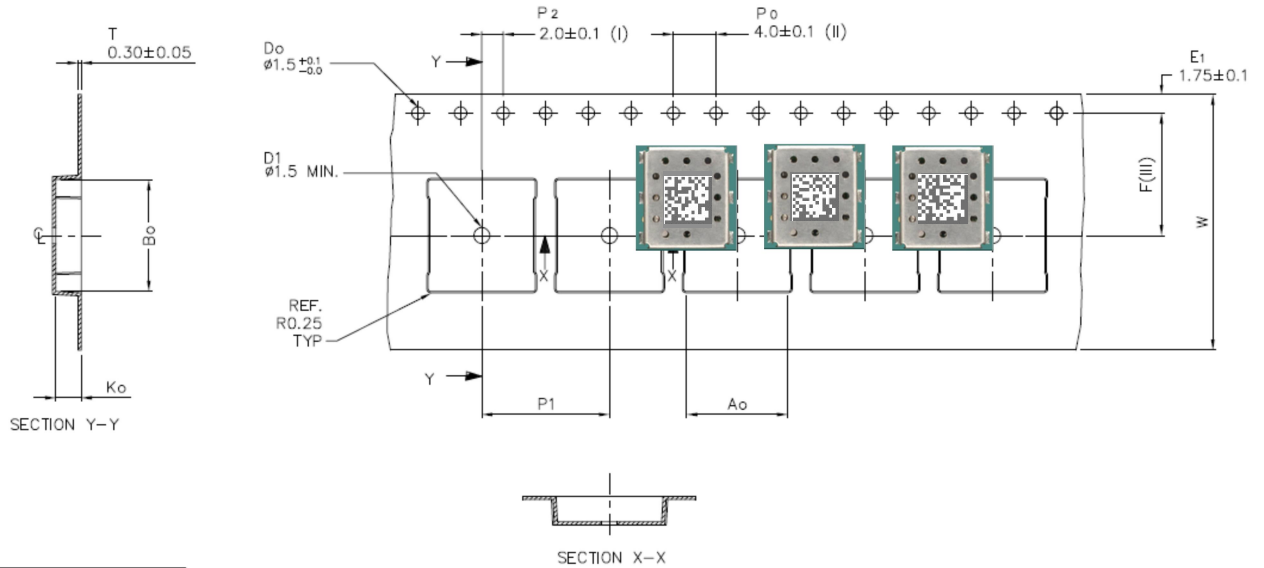

Ao	9.80	+/- 0.1
Bo	10.50	+/- 0.1
Ko	2.40	+/- 0.1
F	11.50	+/- 0.1
P1	12.00	+/- 0.1
W	24.00	+/- 0.3

Forming format : Flatbed
Estimated max. length : 60 meter/22B3 reel

- (I) Measured from centreline of sprocket hole to centreline of pocket.
- (II) Cumulative tolerance of 10 sprocket holes is ± 0.20 .
- (III) Measured from centreline of sprocket hole to centreline of pocket.
- (IV) Other material available.

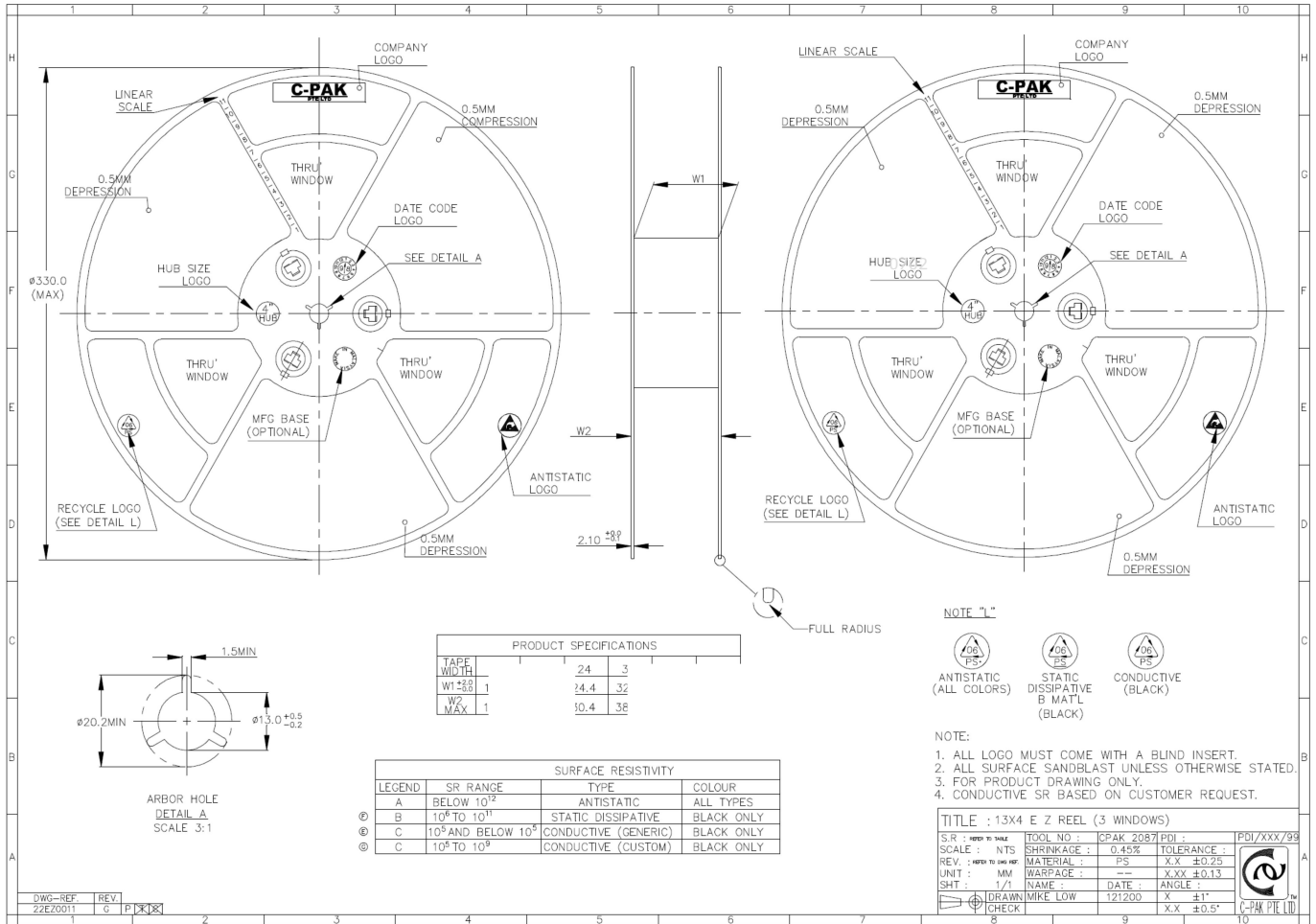

ALL DIMENSIONS IN MILLIMETRES UNLESS OTHERWISE STATED.

17 REEL INFORMATION



no. of devices : 2000 pcs / reel

18 ORDERING INFORMATION

Ordering information			
Type	Part#	Laser marking	Description
TC6000GN-P1 no longer available since Jan.1 2021. See TC6000GN PCN 240726 for more details.	4037735104327 4037735105249	TC6000GN GNS<yy cw> <serial#>	GPS Module with standard options* ¹ , TCXO frequency 26.000MHz
TC6000GN-D Human readable Laser marking of the current production (2024), no longer available for new orders.	4037735106376	 GNS<yy cw> <serial#>	GPS Module with standard options* ¹ , TCXO frequency 26.000MHz
TC6000GN-D Data matrix Laser marking after the production changeover * ²	4037735106376	 Data matrix read as T6D2439100001	GPS Module with standard options* ¹ , TCXO frequency 26.000MHz. T6----- T6 = TC6000GN --D----- = Variant D ---24----- = YY = Year of production -----39----- = WW = Week of production -----100001 = SSSSSS = 6-digit serialnumber

(*1)Note: TC6000GN standard options	
option	comment
Uart Baudrate	9600bps
APM feature	not activated
GPS output rate	1 time per second
NMEA sentences selection	RMC, GGA, GSV, GLL, GSA, VTG
GSV output rate	every second
PPS (pulse per second) out	activated

(*2)Note: see PCN TC6000GN-PCN-241024.
The change will take place in the course of 2025

19 ENVIRONMENTAL INFORMATION

This product is free of environmental hazardous substances and complies to 2015/863/EU. (RoHS 3 directive).

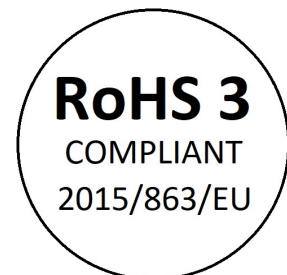

20 Quality and Environmental Specifications

Test	Standard	Parameters
PCB Inspection	IPC-6012B, Class 2. Qualification and Performance Specification for Rigid Printed Boards - Jan 2007	
Assembly Inspection	IPC-A-610-D, Class 2 "Acceptability of electronic assemblies"	
Temperature Range	ETSI EN 300 019-2-7 specification T 7.3	-30 °C, +25 °C, +85 °C, operating
Damp Heat	ETSI EN 300 019-2-7 specification T 7.3	+70 °C, 80% RH, 96 hrs, non-operating
Thermal Shock	ETSI EN 300 019-2-7 specification T 7.3 E	-40 °C ... +85 °C, 200 cycles
Vibration	ISO16750-3	Random vibration, 10~1000Hz, 27.8m/s ² , 8hrs/axis, X, Y, Z 8hrs for each 3 axis non-operating
Shock	ISO16750-3	Half-sinusoidal 50g, 6ms, 10time/face, ±X, ±Y and ±Z non-operating
ESD Sensitivity	JEDEC, JESD22-A114 ESD Sensitivity Testing Human Body Model (HBM), Class 2 JEDEC, JESD22-A115 ESD Sensitivity Testing Machine Model (MM), Class B	+2000V - Human hand assembly +200V - Machine automatic final assembly
Moisture/Reflow Sensitivity	IPC/JEDEC J-STD-020D.1	MSL3
Storage (Dry Pack)	IPC/JEDEC J-STD-033C	MSL3
Solderability	EN/IEC 60068-2-58 Test Td	More than 90% of the electrode should be covered by solder. Solder temperature 245 °C ± 5 °C

Moisture Sensitivity

GNS ships all devices dry packed in tape on reel with desiccant and moisture level indicator sealed in an airtight package. If on receiving the goods the moisture indicator is pink in color or a puncture of the airtight seal packaging is observed, then follow J-STD-033 "Handling and Use of Moisture/Reflow Sensitive Surface Mount Devices".

Storage (Out of Bag)

The TC6000GN-D modules meet MSL Level 3 of the JEDEC specification J-STD-020D – 168 hours Floor Life (out of bag) ≤30 °C/60% RH. If the stated floor life expires prior to reflow process then follow J-STD-033 "Handling and Use of Moisture/Reflow Sensitive Surface Mount Devices".

21 DOCUMENT REVISION HISTORY

V0.1	Nov 2 2010	P.Skaliks	initial
V0.11	Jan 28 2011	P.Skaliks	Internal Objective - Product name extension P1, GPS features added, packing standard , solder profile, factory options
V0.12	Feb 22 2011	P.Skaliks	Objective - GPS features added, factory options,
V0.13	Apr 13,2011	P.Skaliks	reviewed April 13, flash options added
V0.15		P.Skaliks	Pin definitions reviewed and completed. CTS pindefinitionchanged (not connected) .Document Status changed to preliminary
V0.16		P.Skaliks	Pin definitions reviewed and corrected. Modified ordering instructions to short form, laser marking update
V0.18	Nov 2 2011	P.Skaliks	General review
V0.19	Jan 3 2012	M.Reiff	Related documents update
V0.20	May 18 2012	M.Reiff	Laser Marking confirmed; Operating temperature improved; RF input impedance corrected; Navigation sensitivity added; Additional information added for PUSH_TO_FIX, PPS_OUT and FIX_AVAILABLE signal;
V0.21	July 18 2012	W.Koch	Baud rate corrected to 57600 baud, page 20 "customer specific factory settings".
V0.22	Sep 5 2012	P.Skaliks	Format in table "factory option" and explanation for APM on pg 20
V0.23	Dec 6 2012	M.Reiff	Operating temperature deleted at "absolute maximum ratings"; Feature separator changed; Block diagram added
V0.24	Jun 16 2013	P.Skaliks	Corrected typo :thickness in chapter 13, added tolerance information
V0.25	Aug 9, 2013	P.Skaliks	The ordering information was revised
V0.26	Sep 10 2014	P.Skaliks	APM comment added, Outline information revised, Pin description revised
V0.27	July 19 2017	M.Heinzel	Revised Quality and Environmental Specifications New author -> GNS Electronics GmbH
V0.28	Jan 12 2021	M.Heinzel	New product name TC6000GN-x instead of TC6000GN-P1 Switching from unique TCXO to various TCXO frequencies Revision of order information Correction of some spelling mistakes Updated Environmental Information
V2.9	Dec 11 2024	M.Heinzel	More detailed description of the FIX-AVAILABLE signal. Updated Ordering Information. See TC6000GN-PCN-240726.pdf Only TC6000GN-D with 26.000MHz TCXO is available. Customer specific factory options are no longer available. List of RELATED DOCUMENTS updated. Conversion of the DPM from human readable text to machine readable 2D code. See TC6000GN-PCN-241024.pdf

PACKAGING

1 reel		
contents	2,000pcs	
GNS part#	2 x 6550000003 1x 6550000011	
dimensions	dia: 330mm thickness:30.4mm	
gross weight	1.195 Kg	with full contents
net weight	0.246 Kg	
2 vacuum bag		
GNS part#	6550000006	
dimensions	400mm x 480mm	
gross weight	1.321 kg	with full contents
net weight	0.068 Kg	
air pressure level	<30mbar	
3 moisture indicator		
GNS part#	6550000008	
dimensions	76mm x 51mm	
weight	0.001 Kg	
4 dry pack		
GNS part#	6550000007	
dimensions	145mm x 140mm	
weight	0.068 Kg	
5 Box for reel		
GNS part#	6550000012	
dimensions	350 mm x 350mm x 47mm	
gross weight	1.5357 kg	with full contents
net weight	0.184 kg	
6 Outer box		
contents	max 7 box for reel	(14,000 pcs TC6000GN-D)
dimensions	400mm x 370mm x 360mm	
gross weight	11.6 kg	with full contents
net weight	0.85 kg	

22 RELATED DOCUMENTS

Type	description	Available from
TC6000GN_DesignGuide	Contains information about implementation of the module and antenna design	GNS - Electronics GmbH
TC6000GN_EM1_UserManual	Hardware manual for the EM1 Evalboard for TI experimenter boards	GNS - Electronics GmbH
TC6000GN_StarterKit-P1_UserManual	Hardware manual for the GNS Starter Kit	GNS - Electronics GmbH
GPS Antenna Connection Design Guide	Design Guide to implement an GPS antenna to an application PCB	GNS - Electronics GmbH
TC6000GN-PCN-201124	Information about Switching from unique TCXO to various TCXO frequencies	GNS - Electronics GmbH
TC6000GN-PCN-240726	Information about Switching from various TCXO frequencies to unique TCXO frequency	GNS - Electronics GmbH
TC6000GN-PCN-241024	Conversion of the DPM from human readable text to machine readable 2D code.	GNS - Electronics GmbH

The information in this documentation does not form any quotation or contract. Technical data are due to be changed without notice.

GNS electronics or third parties may hold intellectual property rights in the products, names, logos and designs included in this document. Copying, reproduction, or modification of this document or any part thereof is only permitted with the express written permission of GNS electronics. Disclosure to third parties is permitted for clearly public documents only.

The information contained herein is provided "as is" and GNS electronics assumes no liability for its use. No warranty, either express or implied, is given, including but not limited to, with respect to the accuracy, correctness, reliability and fitness for a particular purpose of the information. This document may be revised by GNS electronics at any time without notice. For the most recent documents, visit www.gns-electronics.com.